

STRICTLY PRIVATE & CONFIDENTIAL

Software-Accelerated Electronics Manufacturing

TRANSFORMING PRODUCT DEVELOPMENT WITH SOFTWARE AND AI

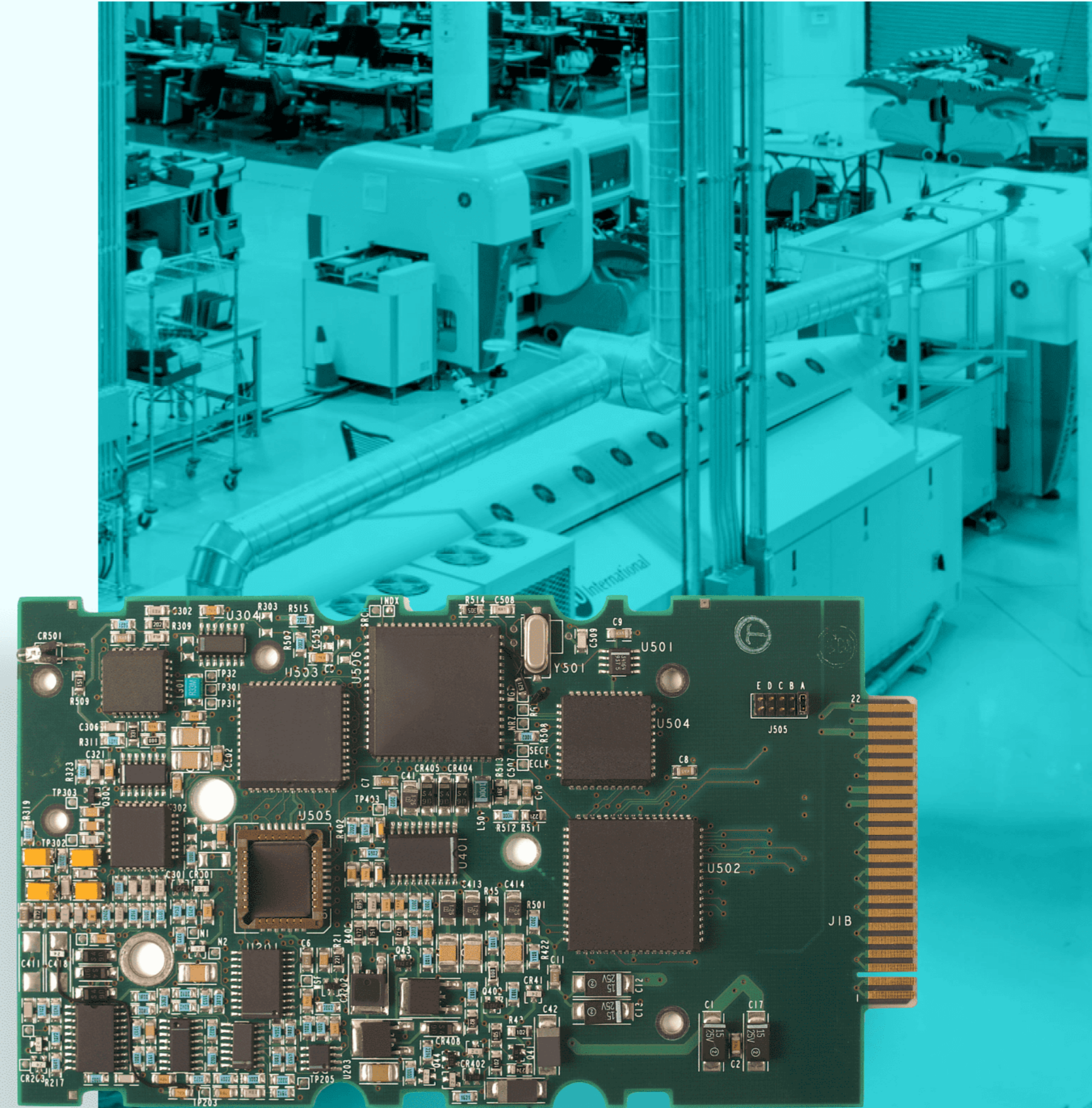
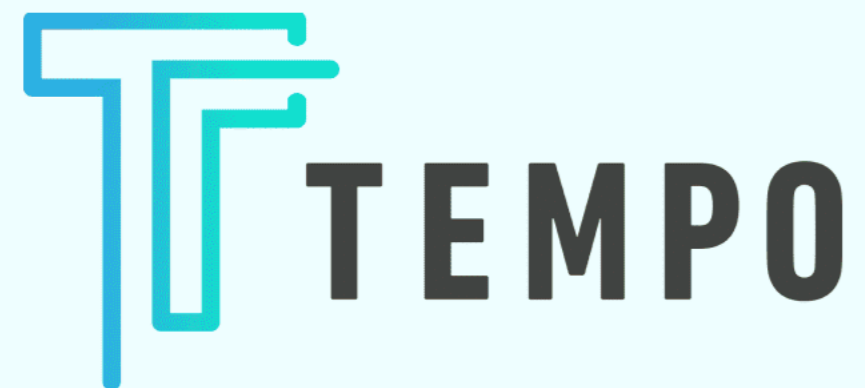

Disclaimer

This presentation (this "Presentation") is provided for informational purposes only and has been prepared to assist interested parties in making their own evaluation with respect to a potential business combination between Tempo Automation, Inc. (collectively with its subsidiaries and pro forma for its acquisition of Compass AC Holdings, Inc. and Whizz Systems, Inc., "Tempo") and ACE Convergence Acquisition Corp. ("ACE", "NASDAQ: ACEV", "NASDAQ: ACEVW", "NASDAQ: ACEVU") and related transactions (the "Proposed Business Combination") and for no other purpose.

No representations or warranties, express or implied are given in, or respect of, this Presentation. This Presentation does not purport to be all-inclusive or to contain all of the information that may be required to make a full analysis of Tempo or the Proposed Business Combination. Viewers of this Presentation should each make their own evaluation of Tempo and of the relevance and adequacy of the information and should make such other investigations as they deem necessary. By reviewing or reading this Presentation, you will be deemed to have agreed to the obligations and restrictions set out below. Without the express prior written consent of ACE and Tempo, this Presentation and any information contained within it may not be (i) reproduced (in whole or in part), (ii) copied at any time, (iii) used for any purpose other than your evaluation of Tempo or (iv) provided to any other person, except your employees and advisors with a need to know who are advised of the confidentiality of the information. This Presentation supersedes and replaces all previous oral or written communications between the parties hereto relating to the subject matter hereof.

Forward-Looking Statements

This document contains certain forward-looking statements within the meaning of the federal securities laws with respect to the Proposed Business Combination, including statements regarding the benefits of the Proposed Business Combination, the anticipated timing of the Proposed Business Combination, the services offered by Tempo and the markets in which it operates, and Tempo's projected future results. These forward-looking statements generally are identified by the words "believe," "project," "expect," "anticipate," "estimate," "intend," "strategy," "future," "opportunity," "plan," "may," "should," "will," "would," "will be," "will continue," "will likely result," and similar expressions. Forward-looking statements are predictions, projections and other statements about future events that are based on current expectations and assumptions and, as a result, are subject to risks and uncertainties. Many factors could cause actual future events to differ materially from the forward-looking statements in this document, including but not limited to: (i) the risk that the Proposed Business Combination may not be completed in a timely manner or at all, which may adversely affect the price of ACE's securities, (ii) the risk that the acquisition by Tempo Automation, Inc. of each of Compass AC Holdings, Inc. and Whizz Systems, Inc. may not be completed in a timely manner or at all, (iii) the risk that the Proposed Business Combination may not be completed by ACE's business combination deadline and the potential failure to obtain an extension of the business combination deadline if sought by ACE, (iv) the failure to satisfy the conditions to the consummation of the Proposed Business Combination, including the receipt of the requisite approvals of ACE's and Tempo's stockholders, the satisfaction of the minimum trust account amount following redemptions by ACE's public shareholders and the receipt of certain governmental and regulatory approvals, (v) the lack of a third party valuation in determining whether or not to pursue the Proposed Business Combination, (vi) the occurrence of any event, change or other circumstance that could give rise to the termination of the agreement and plan of merger, (vii) the effect of the announcement or pendency of the Proposed Business Combination on Tempo's business relationships, performance, and business generally, (viii) risks that the Proposed Business Combination disrupts current plans of Tempo and potential difficulties in Tempo employee retention as a result of the Proposed Business Combination, (ix) the outcome of any legal proceedings that may be instituted against Tempo or against ACE related to the agreement and plan of merger or the Proposed Business Combination, (x) the ability to maintain the listing of ACE's securities on The Nasdaq Stock Market LLC, (xi) the price of ACE's securities may be volatile due to a variety of factors, including changes in the competitive and highly regulated industries in which Tempo plans to operate, variations in performance across competitors, changes in laws and regulations affecting Tempo's business and changes in the combined capital structure, (xii) the ability to implement business plans, forecasts, and other expectations after the completion of the Proposed Business Combination, and identify and realize additional opportunities, and (xiii) the risk of downturns in the highly competitive additive manufacturing industry. The foregoing list of factors is not exhaustive. You should carefully consider the foregoing factors and the other risks and uncertainties described in the "Risk Factors" section of ACE's Annual Report on Form 10-K, Quarterly Reports on Form 10-Q, the Registration Statement (as defined below), the proxy statement/prospectus contained therein, and the other documents filed by ACE from time to time with the U.S. Securities and Exchange Commission (the "SEC"). These filings identify and address other important risks and uncertainties that could cause actual events and results to differ materially from those contained in the forward-looking statements. Forward-looking statements speak only as of the date they are made. Readers are cautioned not to put undue reliance on forward-looking statements, and Tempo and ACE assume no obligation and do not intend to update or revise these forward-looking statements, whether as a result of new information, future events, or otherwise. Neither Tempo nor ACE gives any assurance that either Tempo or ACE, respectively, will achieve its expectations.

Additional Information and Where to Find It

ACE and Tempo and their respective directors and executive officers, under SEC rules, may be deemed to be participants in the solicitation of proxies of ACE's shareholders in connection with the Potential Business Combination. Investors and security holders may obtain more detailed information regarding the names and interests in the Potential Business Combination of ACE's directors and officers in ACE's filings with the SEC, including ACE's registration statement on Form S-1, which was originally filed with the SEC on July 6, 2020. To the extent that holdings of ACE's securities have changed from the amounts reported in ACE's registration statement on Form S-1, such changes have been or will be reflected on Statements of Change in Ownership on Form 4 filed with the SEC. Information regarding the persons who may, under SEC rules, be deemed participants in the solicitation of proxies to ACE's shareholders in connection with the Potential Business Combination is set forth in the proxy statement/prospectus on Form S-4 for the Proposed Business Combination (the "Registration Statement"), which is expected to be filed by ACE with the SEC. ACE will also file other documents regarding the Proposed Business Combination with the SEC. Before making any voting decision, investors and security holders of ACE and Tempo are urged to read the Registration Statement, the proxy statement/prospectus contained therein, and all other relevant documents filed or that will be filed with the SEC in connection with the Proposed Business Combination as they become available because they will contain important information about the Proposed Business Combination.

Investors and security holders will be able to obtain free copies of the proxy statement/prospectus and all other relevant documents filed or that will be filed with the SEC by ACE through the website maintained by the SEC at www.sec.gov. In addition, the documents filed by ACE may be obtained free of charge from ACE's website at www.acev.io or by written request to ACE at ACE Convergence Acquisition Corp., 1013 Centre Road, Suite 403S, Wilmington, DE 19805.

INVESTMENT IN ANY SECURITIES DESCRIBED HEREIN HAS NOT BEEN APPROVED OR DISAPPROVED BY THE SEC OR ANY OTHER REGULATORY AUTHORITY NOR HAS ANY AUTHORITY PASSED UPON OR ENDORSED THE MERITS OF THE OFFERING OR THE ACCURACY OR ADEQUACY OF THE INFORMATION CONTAINED HEREIN. ANY REPRESENTATION TO THE CONTRARY IS A CRIMINAL OFFENSE

Participants in Solicitation

ACE and Tempo and their respective directors and officers may be deemed to be participants in the solicitation of proxies from ACE's stockholders in connection with the Proposed Business Combination. Information about ACE's directors and executive officers and their ownership of ACE's securities is set forth in ACE's filings with the SEC, including ACE's Annual Report on Form 10-K for the fiscal year ended December 31, 2020, which was filed with the SEC on March 26, 2020. To the extent that holdings of ACE's securities have changed since the amounts printed in ACE's Annual Report on Form 10-K for the fiscal year ended December 31, 2019, which was filed with the SEC on March 17, 2021 and subsequently amended on May 6, 2021, such changes have been or will be reflected on Statements of Change in Ownership on Form 4 filed with the SEC. Additional information regarding the interests of those persons and other persons who may be deemed participants in the Proposed Business Combination may be obtained by reading the proxy statement/prospectus regarding the Proposed Business Combination when it becomes available. You may obtain free copies of these documents as described in the preceding paragraph.



Disclaimer (continued)

Industry and Market Data

This presentation has been prepared by Tempo and ACE and includes market data and other statistical information from sources believed by Tempo and ACE to be reliable, including independent industry publications, governmental publications or other published independent sources. Some data is also based on the good faith estimates of Tempo or ACE, which in each case are derived from its review of internal sources as well as the independent sources described above. Although Tempo and ACE believe these sources are reliable, Tempo and ACE have not independently verified the information and cannot guarantee its accuracy and completeness.

Financial Information; Non-GAAP Financial Measures

The financial information and data contained in this Presentation is unaudited and does not conform to Regulation S-X. Accordingly, such information and data may not be included in, may be adjusted in or may be presented differently in the Registration Statement to be filed by ACE with the SEC and the proxy statement/prospectus contained therein. Some of the financial information and data contained in this Presentation, such as EBITDA, EBITDA Margin, Free Cash Flow, Free Cash Flow Conversion, Non-GAAP Operating Expenses, Non-GAAP Gross Profit, Non-GAAP Gross Margin, Non-GAAP Operating Profit, and Non-GAAP Operating Margin has not been prepared in accordance with United States generally accepted accounting principles ("GAAP"). Tempo and ACE believe these non-GAAP measures of financial results provide useful information to management and investors regarding certain financial and business trends relating to Tempo's financial condition and results of operations. Tempo's management uses these non-GAAP measures for trend analyses and for budgeting and planning purposes.

Tempo and ACE believe that the use of these non-GAAP financial measures provides an additional tool for investors to use in comparing Tempo's financial condition and results of operations with other similar companies, many of which present similar non-GAAP financial measures to investors. Management does not consider these non-GAAP measures in isolation or as an alternative to financial measures determined in accordance with GAAP. The principal limitation of these non-GAAP financial measures is that they exclude significant expenses and income that are required by GAAP to be recorded in Tempo's financial statements. In addition, they are subject to inherent limitations as they reflect the exercise of judgments by management about which expenses and income are excluded and included in determining these non-GAAP financial measures. In order to compensate for these limitations, management presents non-GAAP financial measures in connection with GAAP results. You should review Tempo's audited financial statements, which will be included in the Registration Statement.

No Offer or Solicitation

This Presentation shall not constitute an offer to sell or the solicitation of an offer to buy any securities, nor shall there be any sale of securities in any jurisdiction in which such offer, solicitation or sale would be unlawful prior to registration or qualification under the securities laws of any such jurisdiction. This Presentation does not constitute either advice or a recommendation regarding any securities. Any offer to sell securities will be made only pursuant to a definitive Subscription Agreement and will be made in reliance on an exemption from registration under the Securities Act of 1933, as amended, for offers and sales of securities that do not involve a public offering. ACE and Tempo reserve the right to withdraw or amend for any reason any offering and to reject any Subscription Agreement for any reason. The communication of this Presentation is restricted by law; it is not intended for distribution to, or use by any person in, any jurisdiction where such distribution or use would be contrary to local law or regulation.

Use of Projections

This Presentation contains projected financial information with respect to Tempo and ACE. The pro forma numbers and projected financial information of Tempo Automation, Inc. in this presentation are pro forma for the acquisition by Tempo Automation, Inc. of Compass AC Holdings, Inc. and Whizz Systems, Inc., except where stated otherwise. The projected financial information constitutes forward-looking information and is for illustrative purposes only and should not be relied upon as necessarily being indicative of future results. The assumptions and estimates underlying such financial forecast information are inherently uncertain and are subject to a wide variety of significant business, economic, competitive and other risks and uncertainties. See "Forward-Looking Statements" above. Actual results may differ materially from the results contemplated by the financial forecast information contained in this Presentation, and the inclusion of such information in this Presentation should not be regarded as a representation by any person that the results reflected in such forecasts are achieved.

Trademarks

This Presentation contains trademarks, service marks, trade names and copyrights of ACE, Tempo and other companies, which are the property of their respective owners. The use or display of third parties' trademarks, service marks, trade names or products in this presentation is not intended to, and does not imply, a relationship with ACE or Tempo, or an endorsement or sponsorship by or of ACE or Tempo. Solely for convenience, the trademarks, service marks, trade names and copyrights referred to in this presentation may appear without the TM, SM, ® or © symbols, but such references are not intended to indicate, in any way, that ACE or Tempo will not assert, to the fullest extent under applicable law, their rights or the right of the applicable licensor to these trademarks, service marks, trade names and copyrights.



Our Presenters Today

TEMPO EXECUTIVES



Joy Weiss
PRESIDENT & CEO



Ryan Benton
CHIEF FINANCIAL OFFICER



Jeff Kowalski
CHIEF PRODUCT OFFICER



Behrooz Abdi
CHAIRMAN & CEO



ACE EXECUTIVE



ACE Overview

AT A GLANCE

Mandate

Identify and acquire emerging leader in IT infrastructure and SoC markets

~\$230M¹
held in trust

Backed by cross-border Tech PE Manager, ACE Equity Partners, which has led more than \$1B in transactions across its investments

LED BY OPERATORS WITH DEEP DOMAIN EXPERTISE



Behrooz Abdi

Chairman & CEO

35 years of semis experience

Experienced Chairman & CEO with a history of monetizing public and private companies



Denis Tse

Secretary & Director

Cross-border technology investor



KEY BOARD MEMBERS

Omid Tahernia

Ex Corp VP of Xilinx Processing Solutions

Ken Klein

Ex Chairman & CEO, WindRiver

Ryan Benton²

CFO of Tempo Automation

Raquel Chmielewski

Dir. of Investments Council on Foreign Relations

MANAGEMENT TEAM TRACK RECORD



- NetLogic's acquisition of RMI in 2009 in a transaction valued at approximately \$200M contributed meaningfully to NetLogic's eventual \$3.7B acquisition by Broadcom in 2011
- Mr. Abdi led the multi-core processor business unit within NetLogic during its integration period, capturing over 95% of revenue target, thus earning the majority of deal earn-out



- Transaction value of \$1.3B (May 18, 2017)
- Organic growth, diversification, and acquisitions transformed InvenSense into a sensor system leader



¹ Assumes no redemptions by ACE existing shareholders. The trust account includes approximately \$8.1M in deferred underwriting fees that will be payable to the underwriters of ACE's initial public offering in the event that the business combination is completed.
² Mr. Benton has recused himself from negotiations or deliberations on behalf of ACE given his position as an officer at Tempo.

Tempo Automation + ACE: Value-added Partnership



NASDAQ: ACEV, ACEVW, ACEVU

SOFTWARE-ACCELERATED ELECTRONICS MANUFACTURING,
TRANSFORMING PRODUCT DEVELOPMENT WITH SOFTWARE AND AI

UNIQUE BLEND OF DOMAIN EXPERTISE
AND TRACK RECORD OF SCALING COMPANIES

- ✓ Leveraged by many of the world's most innovative companies to **get products to market faster**
- ✓ **Proprietary software platform, with AI that learns from every order, redefines the customer journey** and accelerates time-to-market
- ✓ The platform's all-digital process automation, data-driven intelligence, and connected smart factory **create a breakthrough competitive advantage for customers**
- ✓ Team of operators with **decades of combined experience** in the semiconductor and software industries
- ✓ **Significant track record** of scaling public and private companies
- ✓ Deep and **extensive relationships in the semiconductor and software ecosystems**

TEMPO IS A RAPIDLY ACCELERATING COMPANY SQUARELY IN THE SWEET SPOT OF ACEV'S EXPERTISE AND SPAC SEARCH CRITERIA



Transaction Overview

BUSINESS OVERVIEW

- Software-accelerated electronics manufacturer leveraged by many of the world's most innovative companies to get products to market faster
- In connection with its business combination with ACE, Tempo expects to acquire two targets, Advanced Circuits and Whizz Systems, creating a vertically integrated, scaled platform poised to capture a fragmented \$290B market¹

CAPITAL STRUCTURE

- Established high margin financial profile with, on a pro forma basis², EBITDA margin³ of 12% in 2021E, and growing to 20% in 2022E
- Post transaction, ~\$65M⁴ incremental cash on balance sheet to accelerate growth

VALUATION

- \$936M pro forma enterprise value
- Attractively-valued entry multiple for a high growth business in a massive market

CASH PROCEEDS

- ACE has \$230M of cash in trust⁴
- PIPE and new debt raise of \$161M from premier institutional investors and technology lenders including ACE Equity Partners (an affiliate of ACE's sponsor), Point72 Ventures Investments, Firsthand Funds, Lux Ventures, Structural Capital, and SQN Venture Partners

¹ IPC 2012-2013, 2018, 2019 Annual Reports and Forecasts for the North American EMS Industry; company estimates.

² Pro forma (PF) figures include the acquisitions of Compass AC Holdings, Inc. ("Advanced Circuits" or "AC") and Whizz Systems, Inc. ("Whizz Systems" or "Whizz") which are expected to close substantially concurrently with the SPAC business combination and exclude estimates of additional future acquisitions.

³ EBITDA and EBITDA margin exclude certain non-cash charges such as depreciation & amortization, interest income & expense, stock-based compensation and other one-time or non-recurring charges. For a reconciliation of EBITDA margin to its most direct comparable GAAP measure, see the appendix.

⁴ Assumes no redemptions by ACE existing shareholders. The trust account includes approximately \$8.1M in deferred underwriting fees that will be payable to the underwriters of ACE's initial public offering in the event that the business combination is completed.



STRICTLY PRIVATE & CONFIDENTIAL

Introduction



Tempo Automation Investment Highlights

- 1 Software-accelerated electronics manufacturing, transforming product development for the world's innovators in a \$290B market¹
- 2 Proprietary software platform, with AI that learns from every order, redefines the customer journey and accelerates time-to-market
- 3 Day 1 profit, growth, and strong margins unlocked by a differentiated customer journey & software-enabled efficiencies
- 4 Accelerated growth and data accrual via tech-enabled M&A in a highly fragmented industry
- 5 Management team with deep industry, public market, and M&A experience

PRO FORMA REVENUE² \$ IN MILLIONS

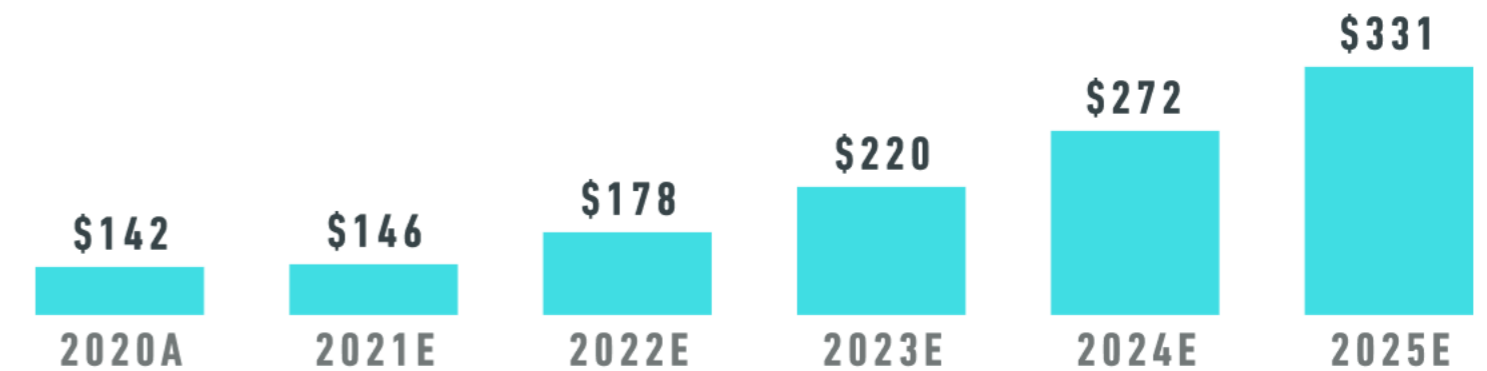

TARGETING AN ADDITIONAL \$300-\$500M+ REVENUE BY 2025 VIA M&A

48%
PF 2022E
GROSS MARGIN²

20%
PF 2022E
EBITDA MARGIN^{2,3}



7,000+
PF 2020 CUSTOMERS²

6
PF MANUFACTURING
FACILITIES²



¹ IPC 2012-2013, 2018, 2019 Annual Reports and Forecasts for the North American EMS Industry; company estimates.

² Pro forma (PF) figures include the acquisitions of Compass AC Holdings, Inc. ("Advanced Circuits" or "AC") and Whizz Systems, Inc. ("Whizz Systems" or "Whizz") which are expected to close substantially concurrently with the SPAC business combination and exclude estimates of additional future acquisitions.

³ EBITDA and EBITDA margin exclude certain non-cash charges such as depreciation & amortization, interest income & expense, stock-based compensation and other one-time or non-recurring charges. For a reconciliation of EBITDA margin to its most direct comparable GAAP measure, see the appendix.

Tempo's Platform Streamlines Electronics Product Realization

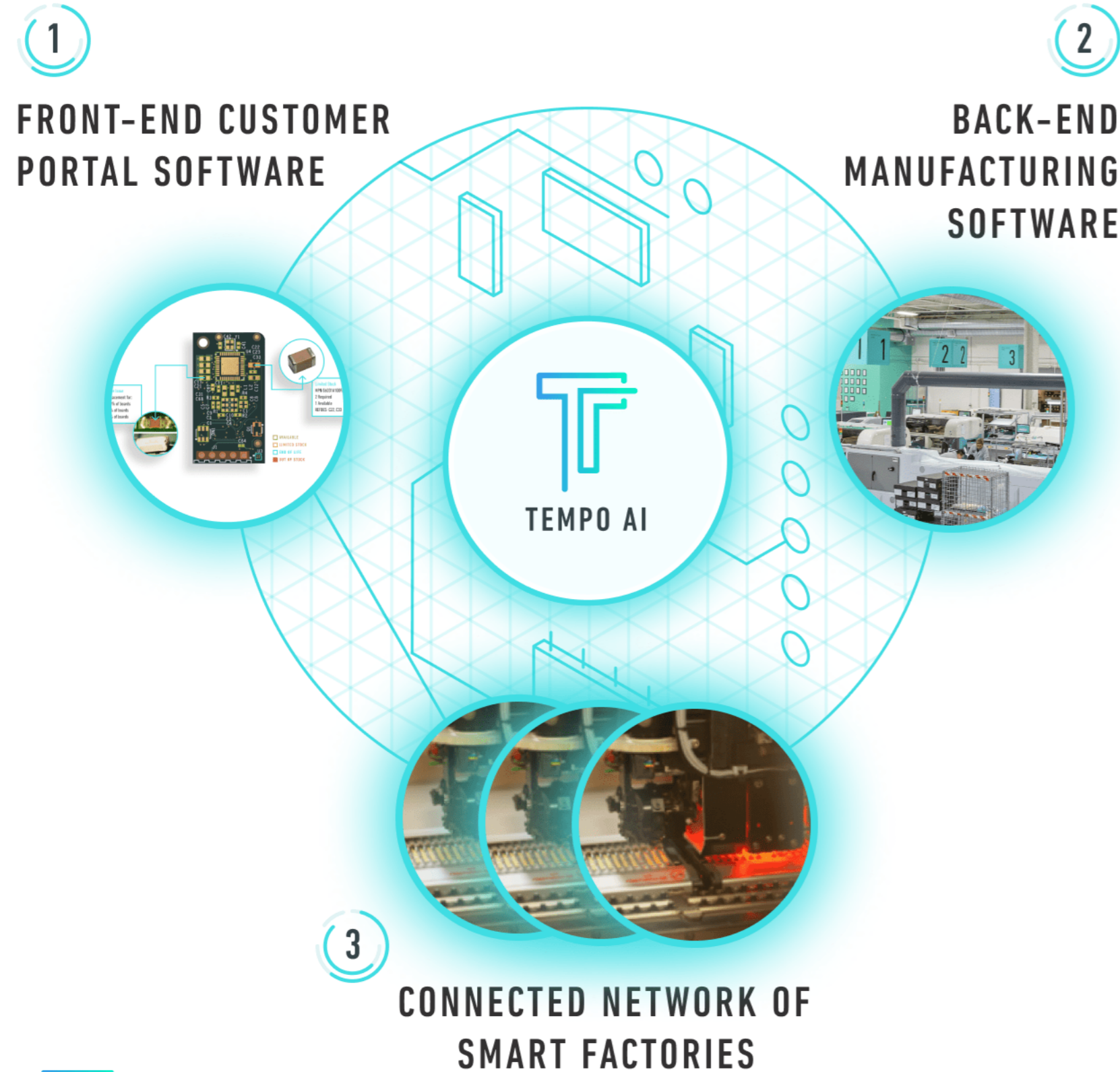

1

Front-end Customer Portal Software

- ✓ Frictionless quoting, ordering, and complex data ingestion via secure cloud-based interface
- ✓ Analysis, interpretation, and visual rendering of engineering, design, and supply chain data
- ✓ Supports engineers in getting to a manufacturable design more quickly and efficiently

2

Back-end Manufacturing Software

- ✓ Continuous, bi-directional digital thread connects customer to the smart factory, weaving together manufacturing processes and design data
- ✓ Data-experienced AI flags and prevents design and production issues
- ✓ Extendable and manageable across multiple sites and locations

3

Connected Network of Smart Factories

- ✓ Turnkey printed circuit board fabrication and assembly
- ✓ Data from every build fuels the AI, increasing efficiencies and streamlining processes



Leadership: Strong Record of Value Creation

MANAGEMENT



JOY WEISS
PRESIDENT, CEO & DIRECTOR
 VP DATA CENTER,
 ANALOG DEVICES
 CEO OF DUST NETWORKS
 (ACQ BY LINEAR TECHNOLOGY)



RYAN BENTON
CHIEF FINANCIAL OFFICER
 CFO/CEO, EXAR
 (ACQ BY MAXLINEAR)
 25+ YEARS OF M&A



JEFF KOWALSKI
CHIEF PRODUCT OFFICER
 CTO, AUTODESK



BILL SCHMITT
CHIEF REVENUE OFFICER
 SVP, MATTERPORT



RALPH RICHART
CHIEF TECHNOLOGY OFFICER
 PRESIDENT, COASTAL
 CIRCUITS (ACQ BY
 ADVANCED CIRCUITS)



MATTIAS CEDERGREN
**CHIEF MANUFACTURING
 OFFICER**
 VP, FLEXTRONICS



DAWN SPRAGUE
VICE PRESIDENT OF PEOPLE
 VP HR, OSISOFT
 (ACQ BY AVEVA)



BOARD OF DIRECTORS



MATTHEW GRANADE
CHAIRMAN OF THE BOARD



SRI CHANDRASEKAR
DIRECTOR



ZAVAIN DAR
DIRECTOR



JEFF MCALVAY
DIRECTOR & CO-FOUNDER



JACKIE SCHNEIDER
DIRECTOR



UNIQUE COMBINATION OF TECHNOLOGY DEVELOPMENT, M&A, AND BUSINESS SCALING EXPERTISE



The Product Development Journey is the Same, Whether the End Goal is 100 units/year or 1M units/year

Each successive iteration progresses a product to manufacturability at volume, and to ensuring it fulfills its ambitious performance goals

Example electronics product development ramp:
Top 5 medical device manufacturer

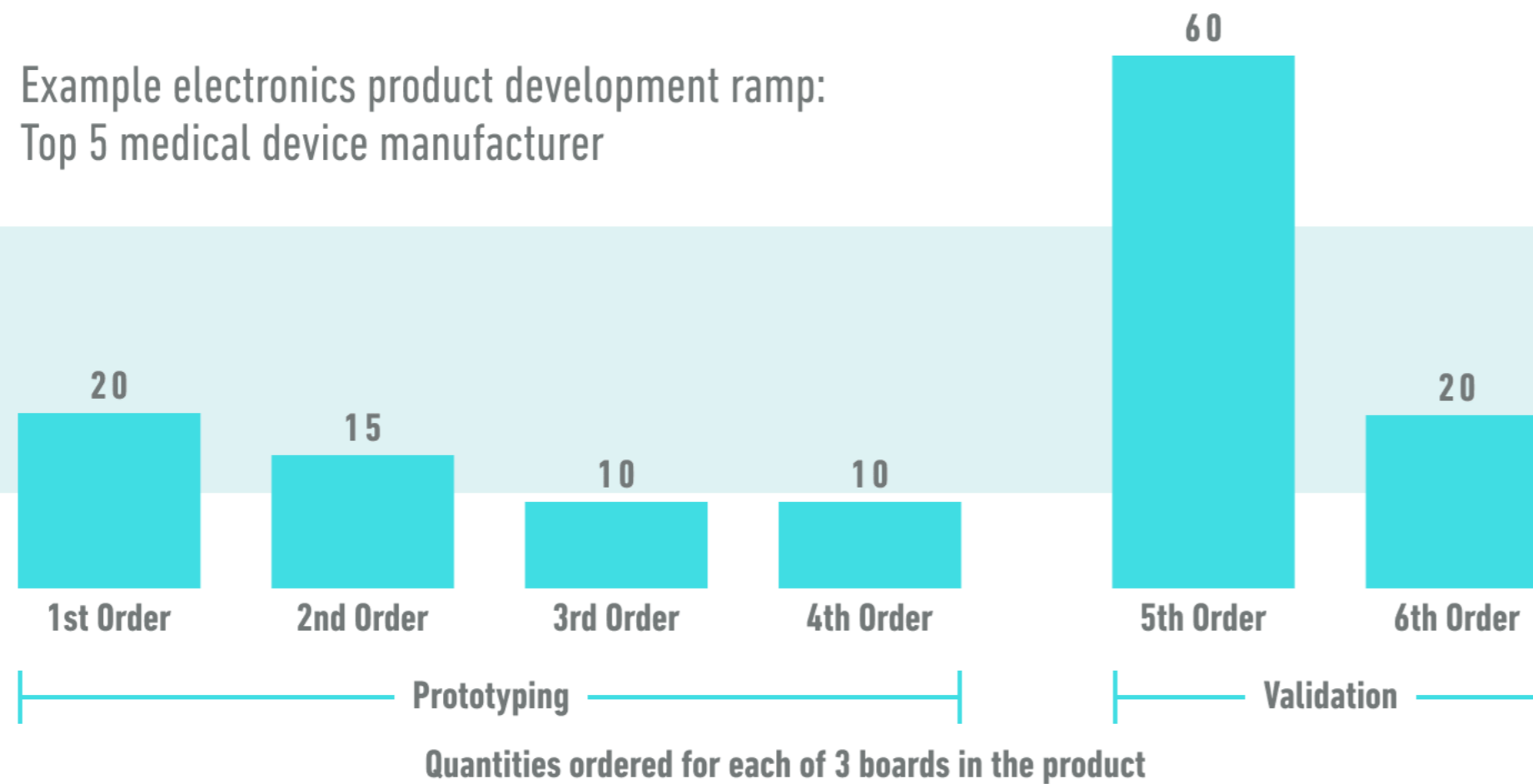

ON-DEMAND
PRODUCTION
< 1000 UNITS



ON-RAMP TO
PRODUCTION

VOLUME
PRODUCTION
1000+ UNITS



3 boards x 6 iterations = 18 iterations for this product. The average electronics product goes through 14 iterations before it gets to market.¹



¹ Aberdeen Group, Why PCB Design Matters to the Executive.

Prototype & On-Demand Production Are Different Than Volume Production

	NON-US MARKET SIZE ¹	US MARKET SIZE ¹	# OF DESIGN ITERATIONS ²	# OF UNIQUE PRODUCTS PER PRODUCTION LINE ²	COMPONENT INVENTORY ²	# CHANGE ORDERS PER ORDER ²	PRIMARY GOAL	
VOLUME PRODUCTION 1,000+ UNITS	\$1.3T	\$60B	1	1 PER SEVERAL MONTHS	Forecasted	0	Minimize cost	VOLUME MANUFACTURER
PROTOTYPE & ON-DEMAND PRODUCTION < 1,000 UNITS	\$375B	\$290B	14	3+ PER DAY	Just-in-time	2-10+	Minimize time to market	TEMPO

Tempo's market



¹ IPC 2012-2013, 2018, 2019 Annual Reports and Forecasts for the North American EMS Industry; IPC LinkedIn; company estimates.

² Illustrative.

The US Outsourced Market is Served Primarily by Small, Owner-Operated Businesses

Aging, expert workforce is retiring, along with their tacit knowledge

~1,100, many of which are owner-operated companies

COMPANIES WITH < \$50M REVENUE

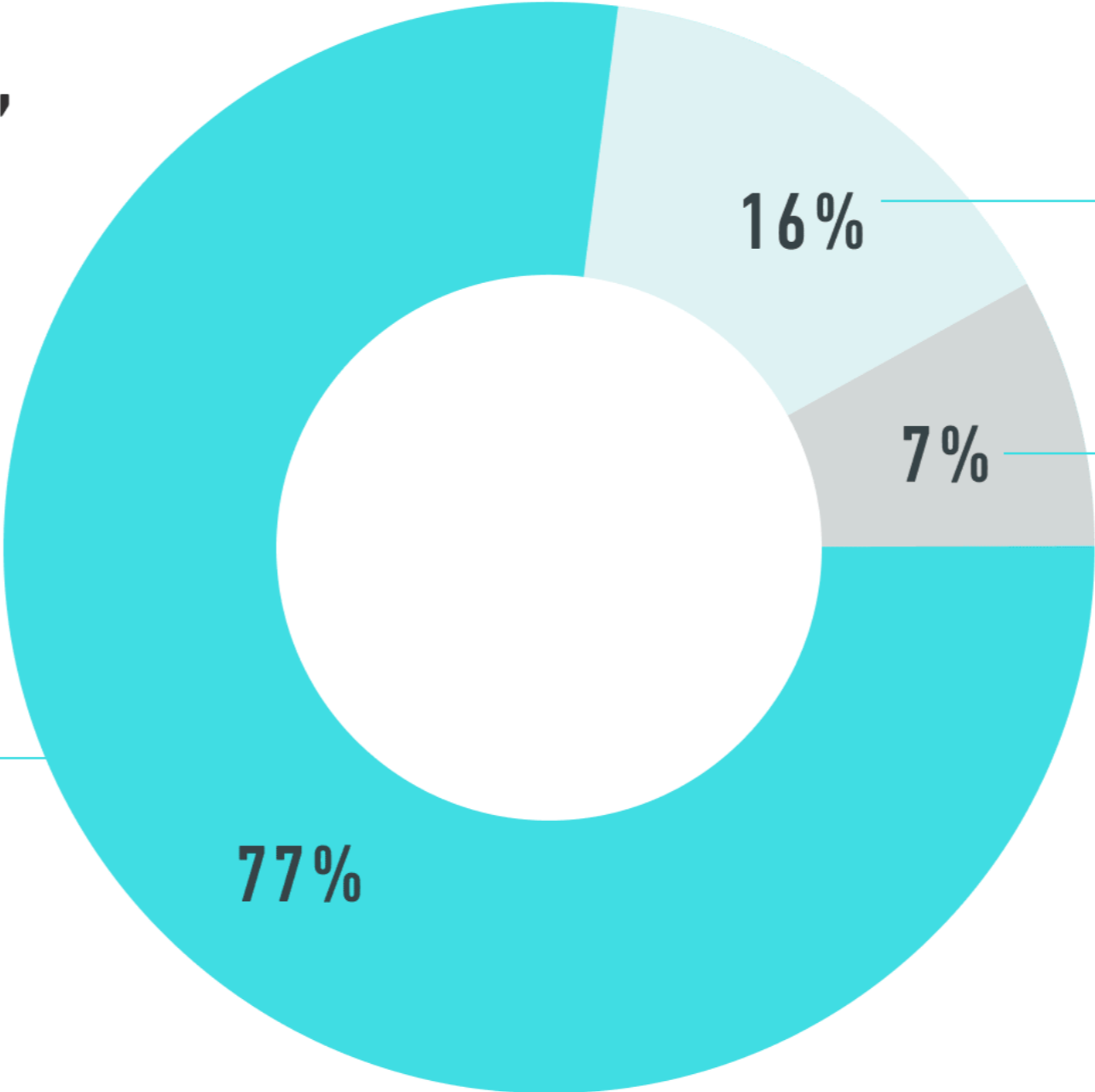

Volume manufacturers often refer out prototyping and on-demand production business

COMPANIES WITH \$500M+ REVENUE

Typically PE rollups of smaller businesses

COMPANIES WITH \$50M - \$500M REVENUE



1 IPC 2019 Annual Report and Forecast for the North American EMS Industry.

US OUTSOURCED ELECTRONIC MANUFACTURER FACILITIES¹

(\$ REPRESENTS ANNUAL REVENUE PER ENTERPRISE)

High-Growth Verticals Require More and More Complex Electronics



Set to grow from \$350B to over \$1T by 2040¹

Expected to reach \$362B by 2025 via a 7.2% CAGR 2020 – 2025²

Estimated to reach \$850B by 2026 via a 9% CAGR 2019 – 2026³

Medical Device industry to be \$600B by 2023 via a 6.1% CAGR 2021 - 2023⁴

Industrial IoT market to reach \$260B by 2027 via a 16.7% CAGR 2020 - 2027⁵

TEMPO CUSTOMERS INCLUDE

4 of the top 5
SPACE COMPANIES⁶

3 of the top 5
SEMICONDUCTOR COMPANIES⁶

4 of the top 5
AVIATION & DEFENSE COMPANIES⁶

4 of the top 5
MEDICAL DEVICE COMPANIES⁶

3 of the top 5
INDUSTRIAL & ECOMMERCE COMPANIES⁶

EXAMPLE TEMPO CUSTOMERS



¹ Morgan Stanley Research, Space: Investing in the Final Frontier.
² McKinsey & Company, McKinsey on Semiconductors.
³ Facts & Factors, Aircraft Manufacturing Market.
⁴ The Business Research Company, Medical Devices Market Opportunities and Strategies.
⁵ Meticulous Market Research, Industrial IoT Market.
⁶ Top companies defined as those with the greatest market capitalization as of September 30, 2021 per FactSet.



Electrical Engineers Have Become Frustrated By an Industry Rife with Quality + On-time Delivery Issues



“I’ve experienced the worst of the worst from other [vendors] in the 8 years I’ve been an [electrical engineer].
I’m floored that you guys delivered on time and with no quality issues.”

Electrical Engineer
Leading commercial space company



“I was pleasantly surprised today with a package from your factory, and I am incredibly pleased to tell you that...**the first articles powered up** and we are live...
We never dreamed of such a smooth take-off.”

Electrical Engineering Lead
Public semiconductor capital equipment component manufacturer

TEMPO DELIVERS A HIGHER STANDARD



Tempo's Software Platform Helps Companies Iterate Faster

STATUS QUO APPROACH¹

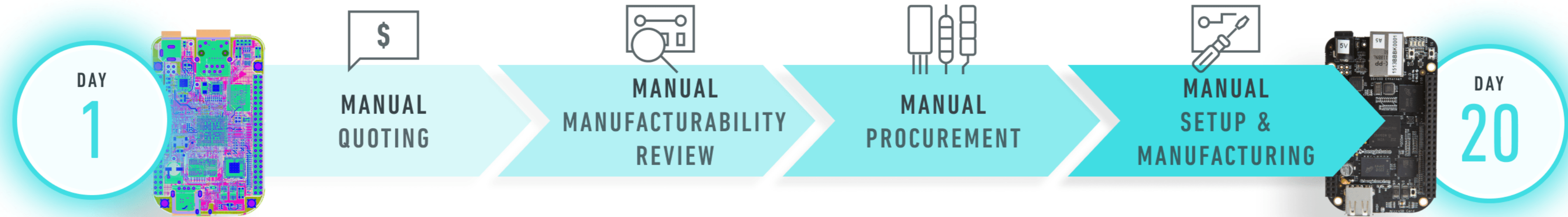

TEMPO APPROACH¹: AUTOMATED, LIGHT-TOUCH, QUICK-TURN, HIGH-QUALITY, SOFTWARE-POWERED MANUFACTURER

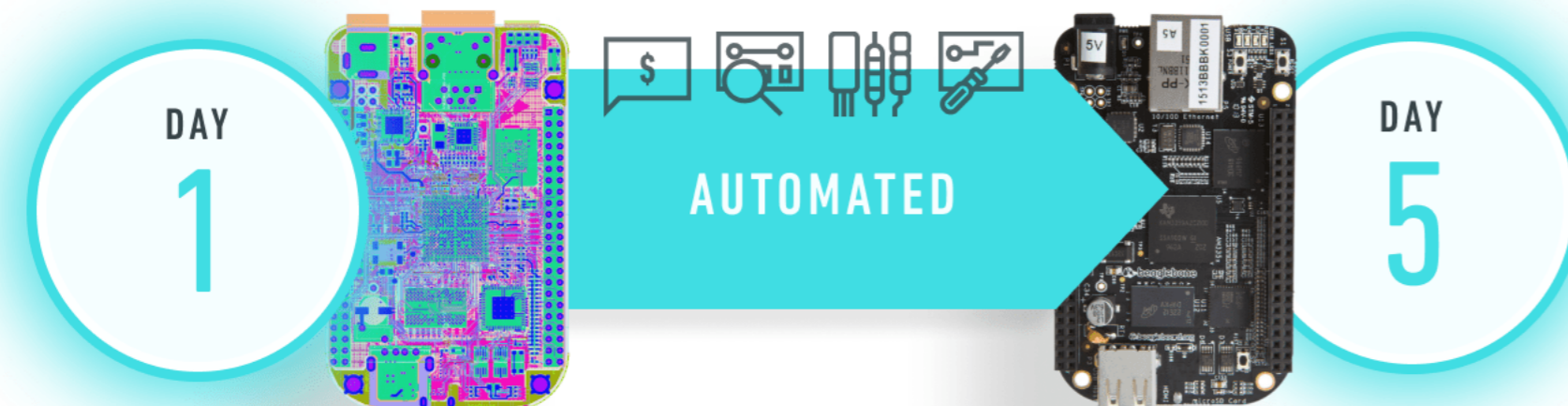

- ✓ AUTOMATED QUOTING
- ✓ AUTOMATED MANUFACTURABILITY REVIEW
- ✓ AUTOMATED PROCUREMENT
- ✓ AUTOMATED SETUP & MANUFACTURING



¹ Illustrative.

Case Study: GE Healthcare Iterates in Days vs. Weeks

STATUS QUO MANUFACTURER

Their previous vendor's lead times were usually 3 - 4 weeks and could take **up to 5 weeks**. Getting a quote for a new design took an entire week. Additionally, the quality was lower than desired.

THE TEMPO EXPERIENCE

Tempo delivered their complex boards within 5 days, which significantly shortened the 'fail and iterate' process, thereby ensuring that they were able to produce a high quality product in a shorter time. Dennis Sauer, Electronics Test Platform Standardization and Design for Test Leader, was "honestly quite shocked..." by Tempo providing his quote within a couple of hours.

"Being able to fail faster had a direct impact on our timeline."
– Jason Metzner, Lead Electrical Engineer, GE Healthcare

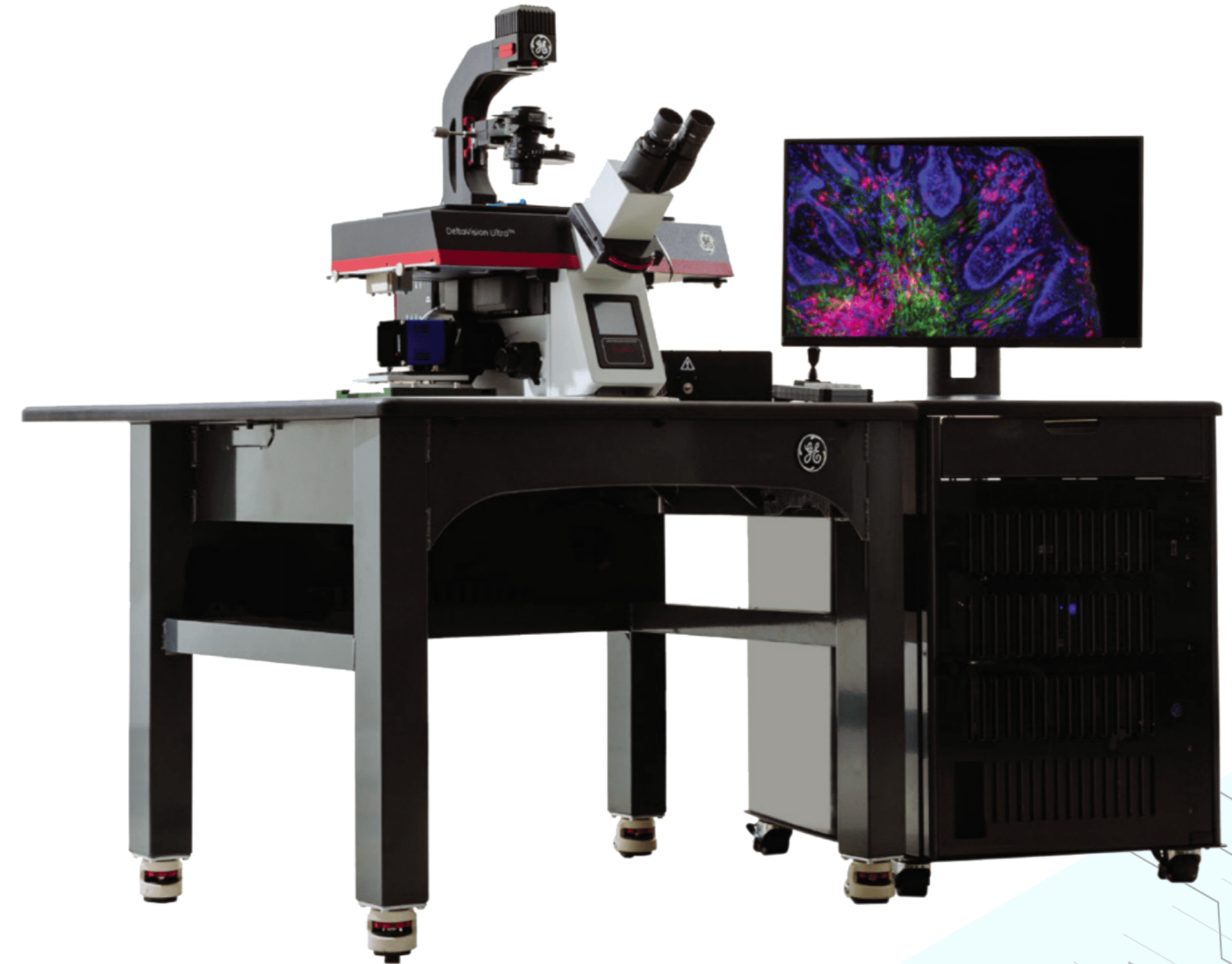

Faster Iterations = Faster Time to Market

EXAMPLE TIME TO MARKET: TOP 5 SPACE, AVIATION, AND DEFENSE COMPANY¹

STATUS QUO



22-24 MONTHS²

USING TEMPO

11 MONTHS²



“Tempo is all about agility, speed, and focus on prototyping. They’ve enabled us to get hardware into our labs and begin integration far faster than traditional sources would.”

Vice President

Top 5 space, aviation, and defense company



¹ Top companies defined as those with the greatest market capitalization as of September 30, 2021 per FactSet.

² Customer-reported.

STRICTLY PRIVATE & CONFIDENTIAL

Technology Platform



A Highly Manual **Status Quo** Slows the Development Process



CAD Software + Design Files → Sent through Various Methods → Reviewed by Humans → Produced Labor-Intensively



**DISCONNECTED PROCESS
IN AN INDUSTRY
UNDERSERVED BY TECHNOLOGY**

- ⊗ SLOW
- ⊗ ARDUOUS
- ⊗ OPAQUE
- ⊗ UNRELIABLE
- ⊗ UNPREDICTABLE QUALITY



Tempo Weaves a Digital Thread, From First Touch to Delivery

Customer journey connected by continuous digital thread, initiated as soon as design is uploaded

Patents underpin algorithms that analyze design, determine component availability, and deliver quote

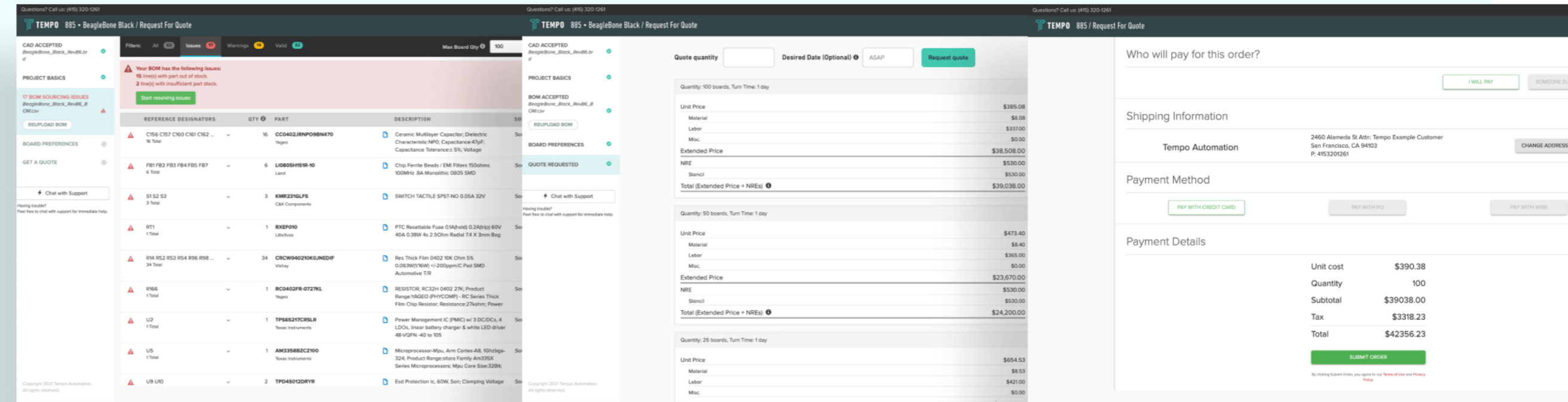
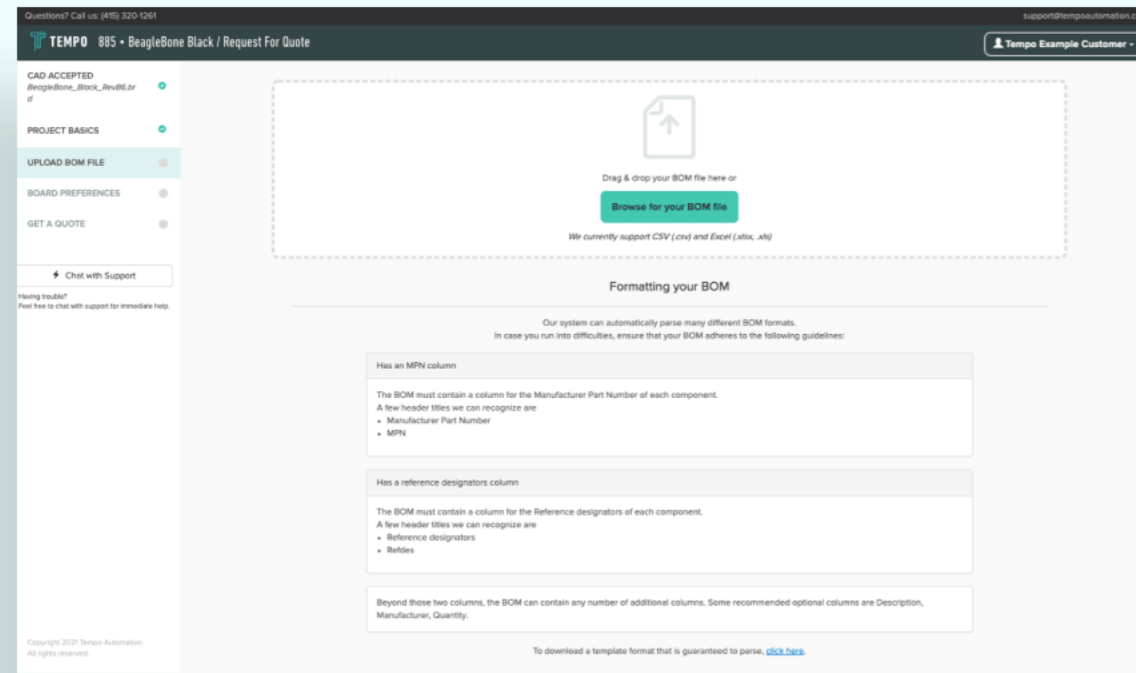

TEMPO
DIGITAL THREAD

Design File Upload



Capture & Preserve
Design Intent



Rapid Quote



Accept PCBA Order



OCTOBER 2021 22
STRICTLY PRIVATE &
CONFIDENTIAL

Tempo Platform Underpins Logistics

Automated analysis confirms manufacturability of design

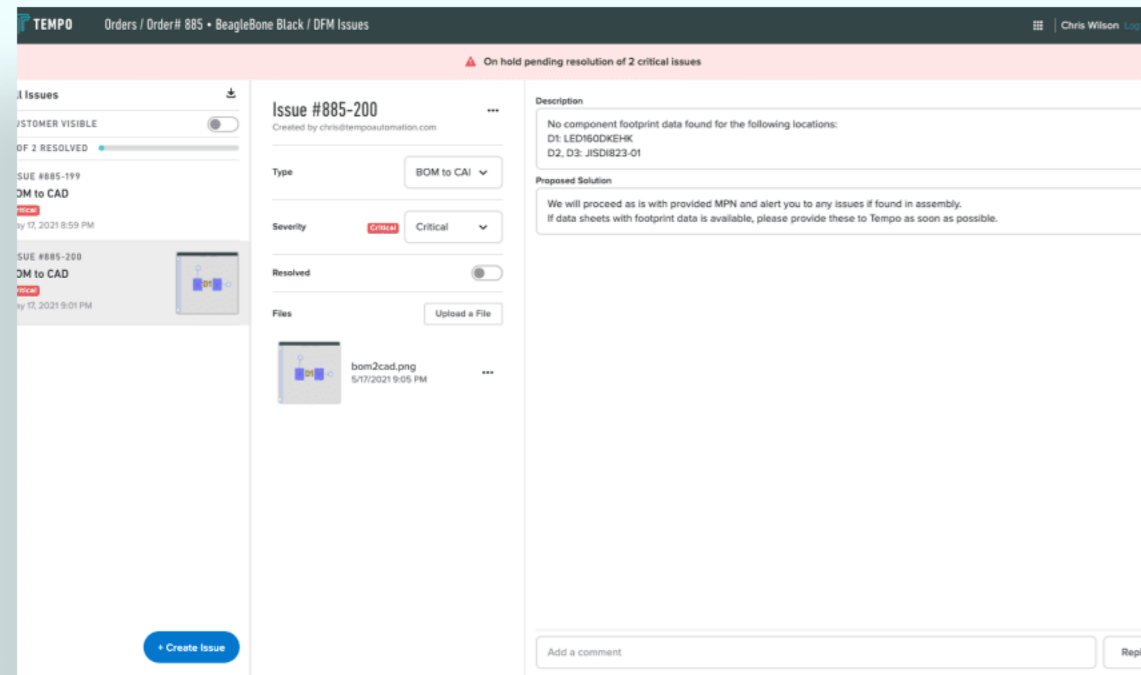

Components ordered via integrated interface with vendors

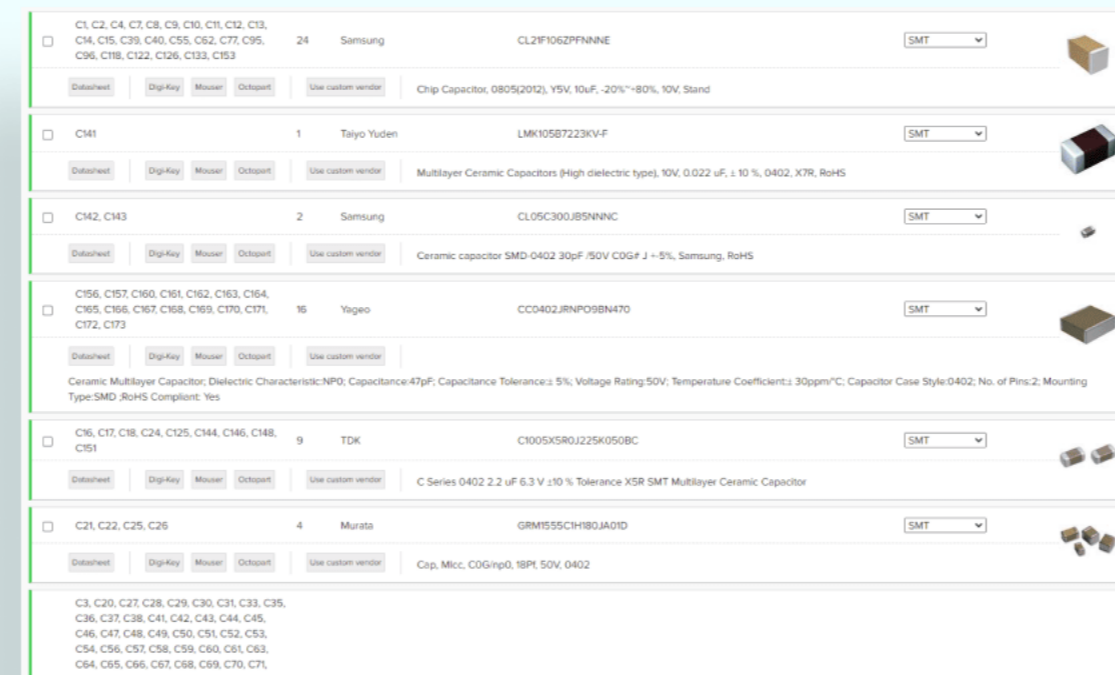

Factory programmed for assembly

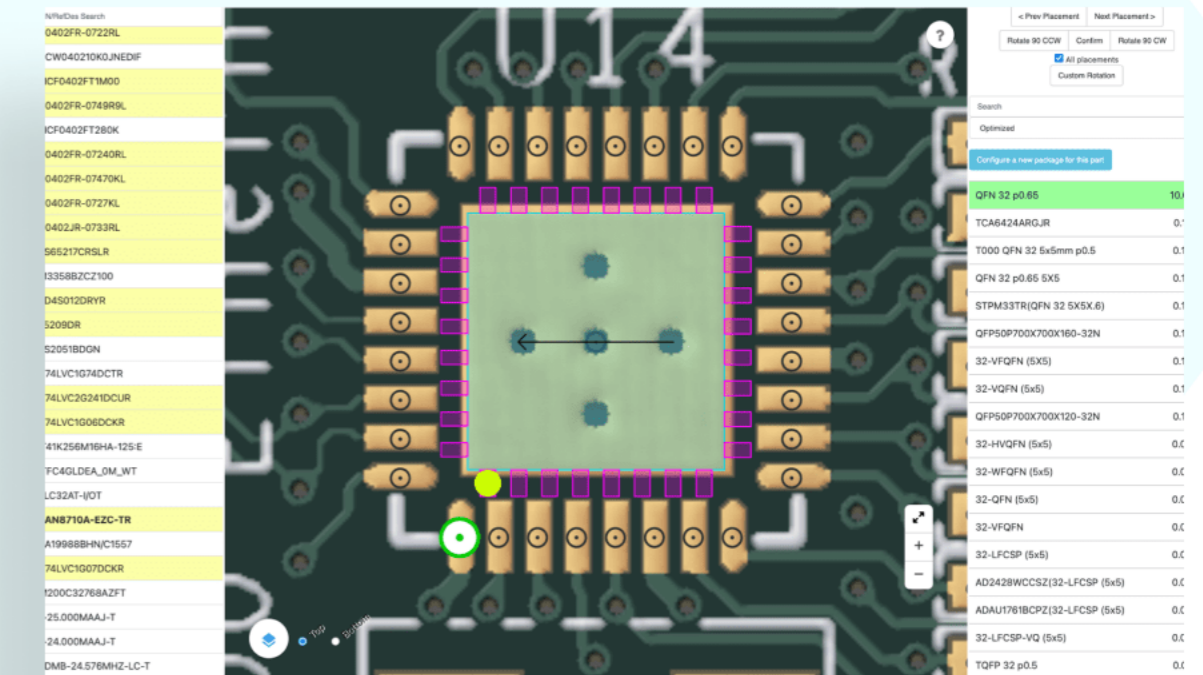

Manufacturability Check & Issue Resolution

Network of Pre-qualified / Audited Raw Material Vendors

Parts Check-In, Machine Programming



Tempo Platform Streamlines Assembly

Automated monitoring of manufacturing execution data drives higher yields

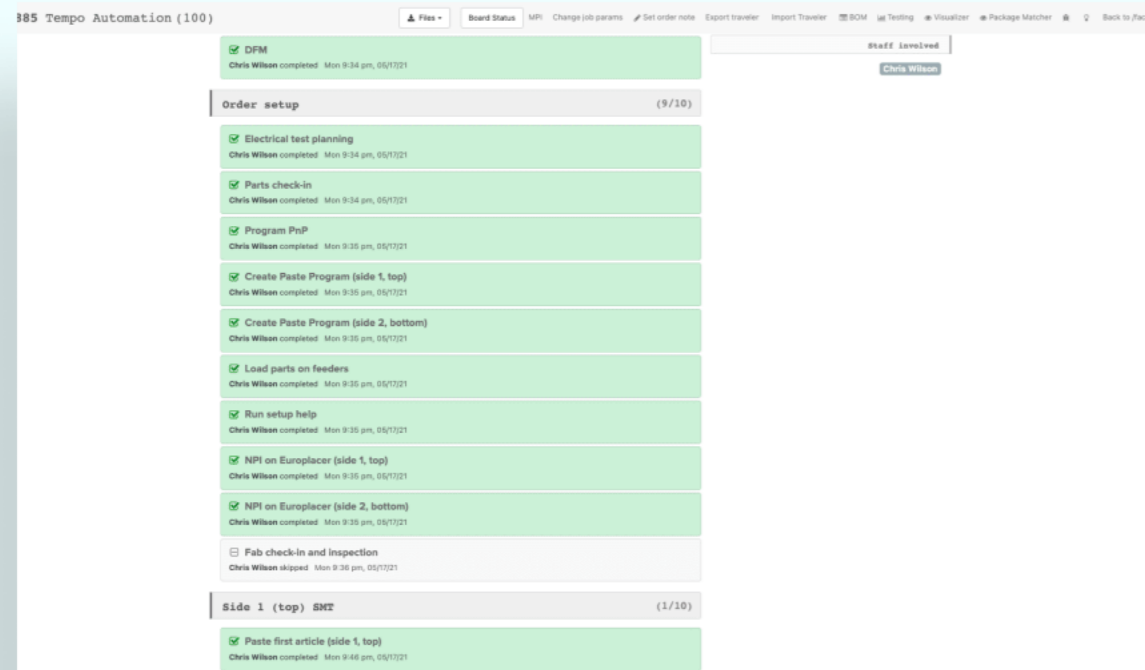

Automated process confirms quality product

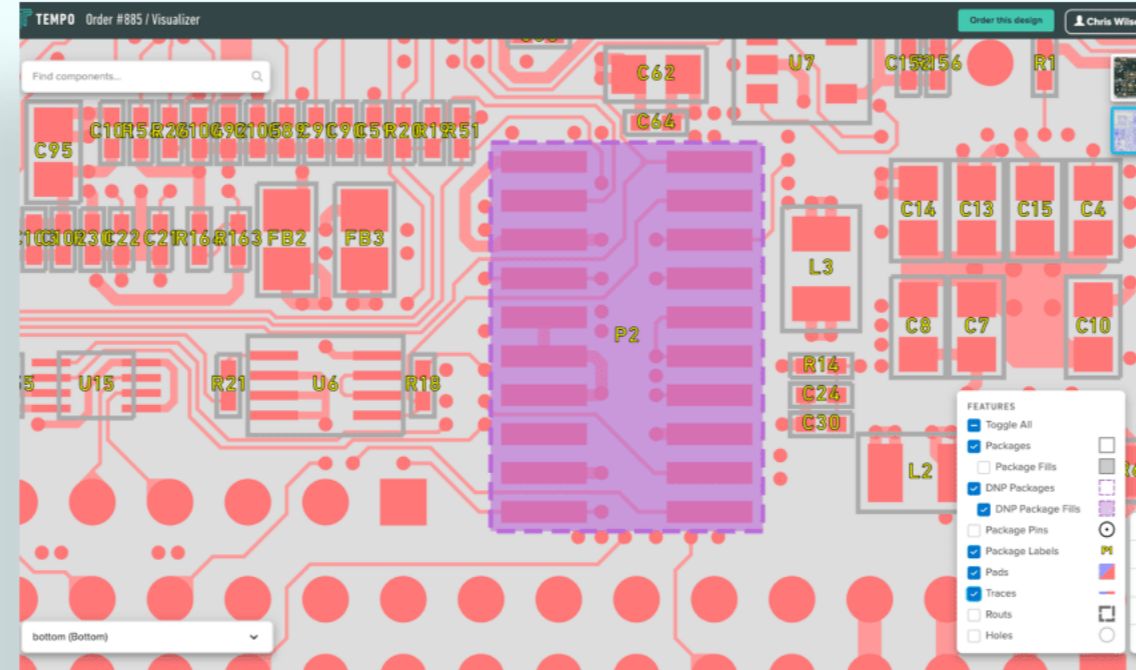

Tracked, on-time shipment

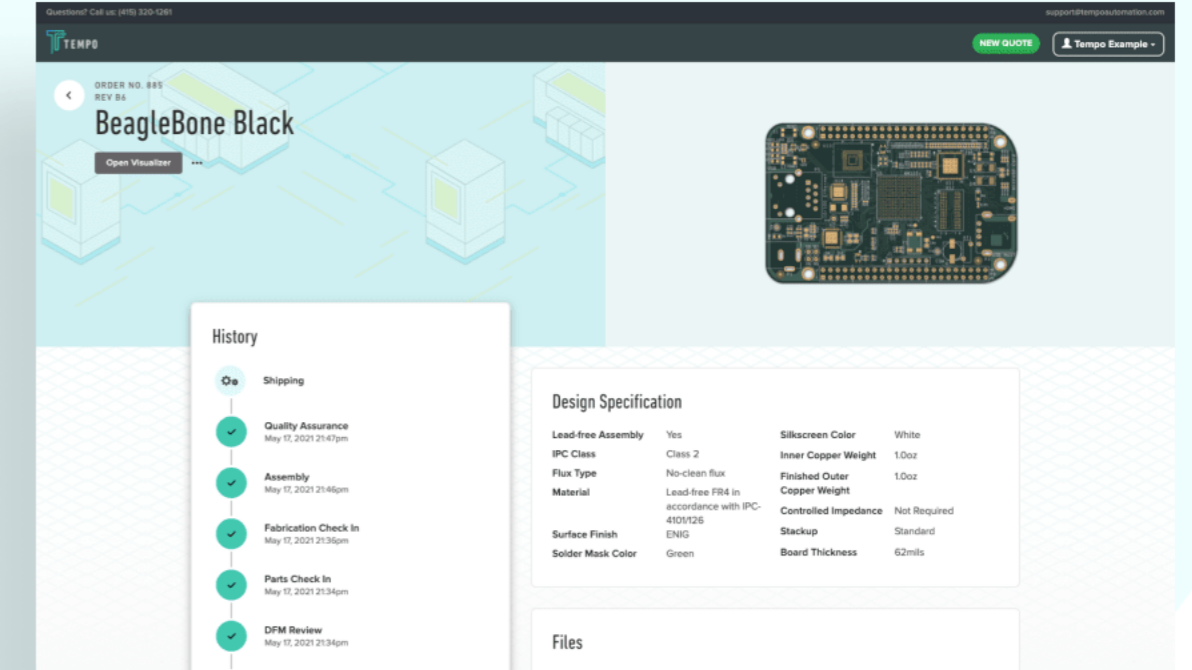

→ Assembly

→ Quality Assurance

→ Delivery



OCTOBER 2021 24
STRICTLY PRIVATE &
CONFIDENTIAL

Tempo Visualizer: Print Preview + Spellcheck for Electronics

Tombstone Issue
On this placement for:
Rev A: 10% of boards
Rev B: 5% of boards
Rev C: 1% of boards

Limited Stock
MPN 06031A100FA12A
2 Required
1 Available
REFDES C22, C33

Legend:
■ AVAILABLE
■ LIMITED STOCK
■ END OF LIFE
■ OUT OF STOCK

Image is illustrative only.



Tempo Roadmap Redefines the Manufacturing Process



STATUS QUO
MANUAL PROCESS

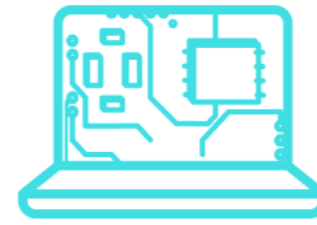

TEMPO
AUTOMATED PROCESS



TEMPO AI
INTELLIGENT PROCESS

DATA

Inconsistent, Incomplete Data

Connected Information

PROCESSES

Disconnected Processes

Digital Thread

- Continuous
- Bi-Directional

PROCESSORS

Human Processors

- Manual Effort
- Tacit knowledge
- Not portable

Cloud-based Distributed
Computation



¹ 9,971,338 and 10,481,585.

Protected by foundational patents¹

STRICTLY PRIVATE & CONFIDENTIAL

Growth: Organic + Inorganic

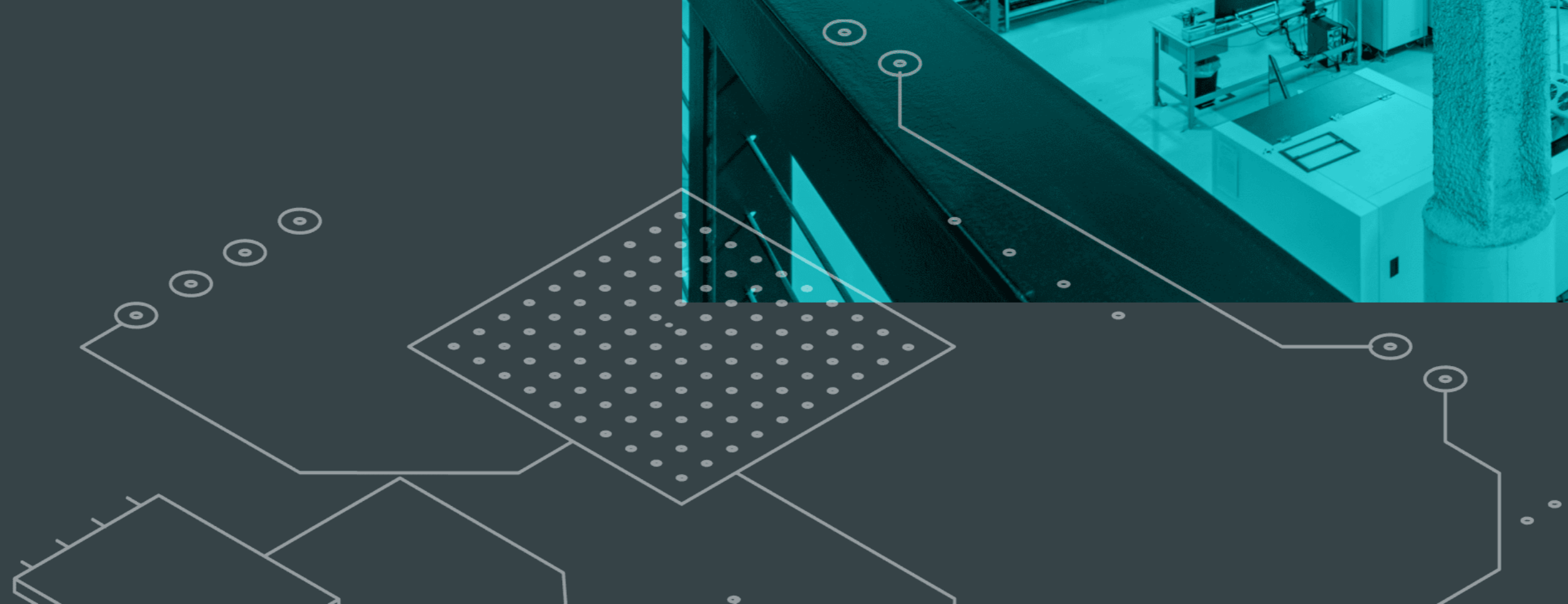

Customers, Technology, and M&A Drive our Growth



Harness our end-to-end, vertically integrated platform

- 7,000+ customer base¹ provides enormous expansion opportunity
- Broader offering benefits existing customers, unlocks new customers and verticals, and opens up cross-selling opportunities
- Deeper supply chain control enhances customer experience and eliminates margin stacking



Enhance our automated, intelligent process

- More orders imply more data; more data further improves customer experience and drives more orders - a virtuous cycle
- Additional gross profit enables accelerated R&D investment in our software platform
- Tempo's software platform confers top-line and bottom-line benefits to targets



Continue to make disciplined inorganic investments

- \$290B fragmented landscape² presents significant future growth opportunity via tech-enabled M&A
- Highly active pipeline with 100+ opportunities identified
- Leadership team with decades of experience acquiring and integrating businesses



¹ Pro forma (PF) figures include the acquisitions of Compass AC Holdings, Inc. ("Advanced Circuits" or "AC") and Whizz Systems, Inc. ("Whizz Systems" or "Whizz") which are expected to close substantially concurrently with the SPAC business combination and exclude estimates of additional future acquisitions. 2020 customer count.

² IPC 2012-2013, 2018, 2019 Annual Reports and Forecasts for the North American EMS Industry; company estimates.

Blue Chip Customer Base Provides Significant Growth Headroom

With 7,000+ customers¹, if all we do is grow within them, we will have an enormous business

LAND AND EXPAND EXAMPLE: LEADING COMMERCIAL SPACE COMPANY

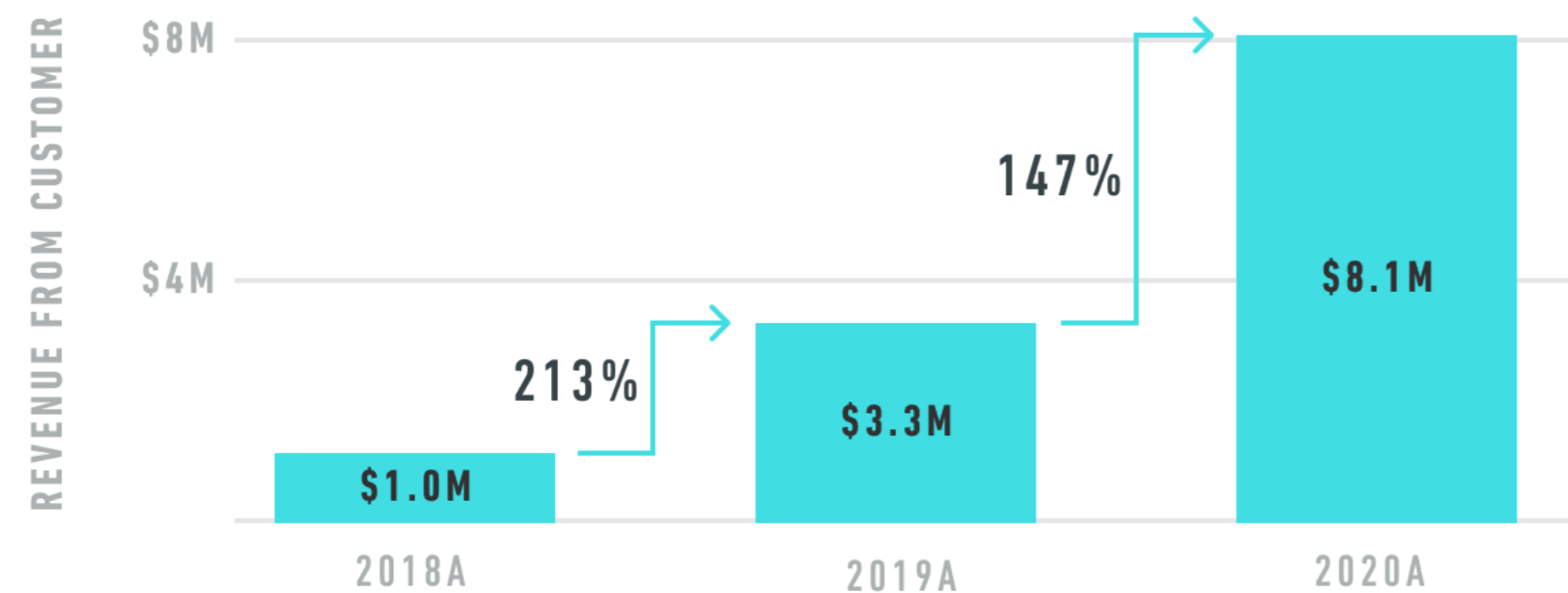

\$60M²

ESTIMATED ELECTRONICS PROTOTYPING & ON-DEMAND PRODUCTION SPENDING IN ACCOUNT

LAND AND EXPAND EXAMPLE: LEADING ELECTRIC CAR COMPANY

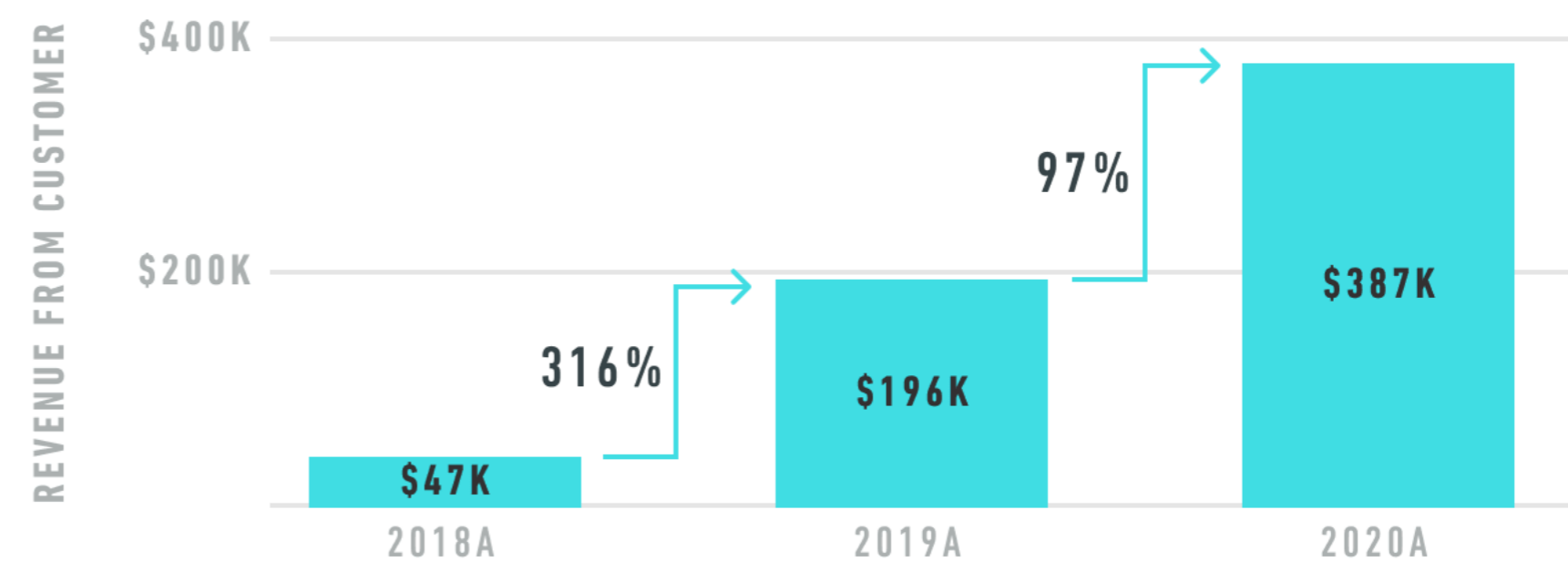

\$50M²

ESTIMATED ELECTRONICS PROTOTYPING & ON-DEMAND PRODUCTION SPENDING IN ACCOUNT



¹ Pro forma (PF) figures include the acquisitions of Compass AC Holdings, Inc. ("Advanced Circuits" or "AC") and Whizz Systems, Inc. ("Whizz Systems" or "Whizz") which are expected to close substantially concurrently with the SPAC business combination and exclude estimates of additional future acquisitions. 2020 customer count.

² Company estimates.

Initial Acquisitions Position Tempo to Transform Every Step of the Electronics Development Process

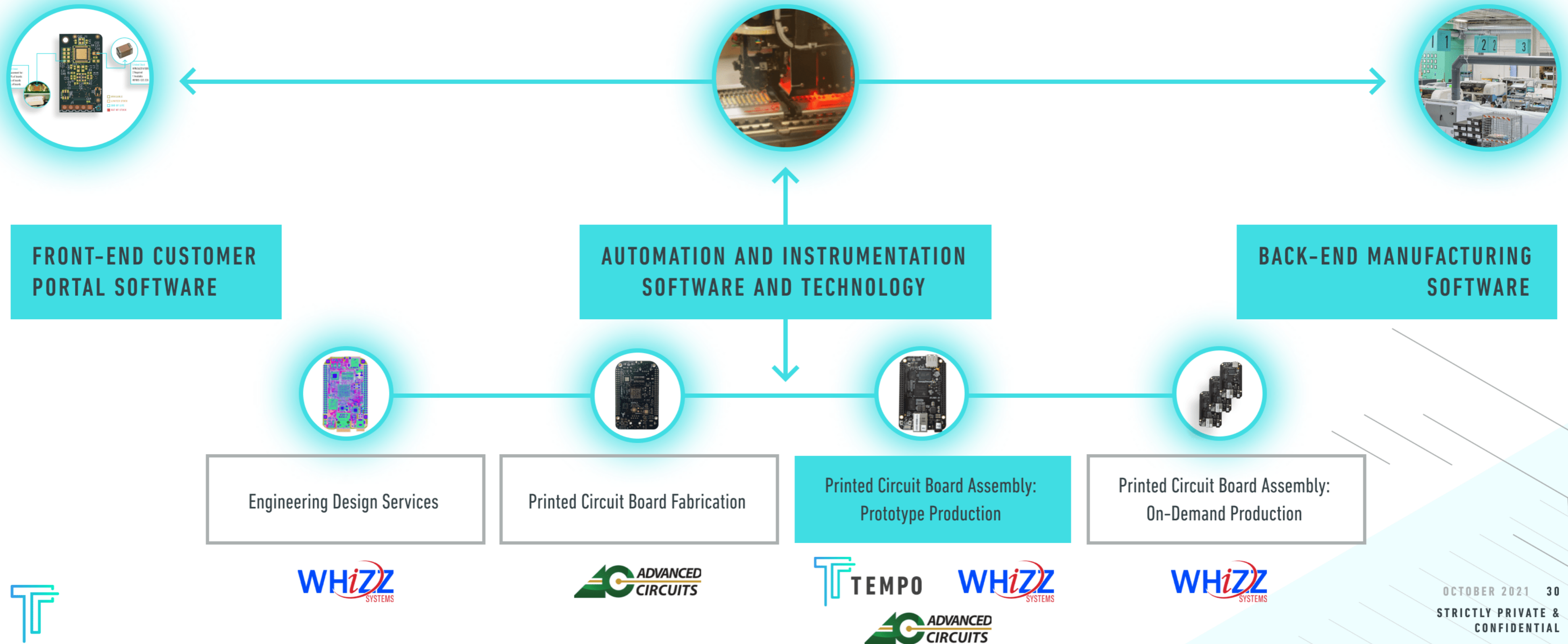

Tempo's Platform Drives Growth and Profitability in Targets

TOP LINE BENEFITS TO ACQUIRED COMPANIES

Customer Portal helps acquired companies unlock growth in new and existing accounts

FRONT-END CUSTOMER PORTAL SOFTWARE

Self-service customer interactions reduce the costs associated with executing orders

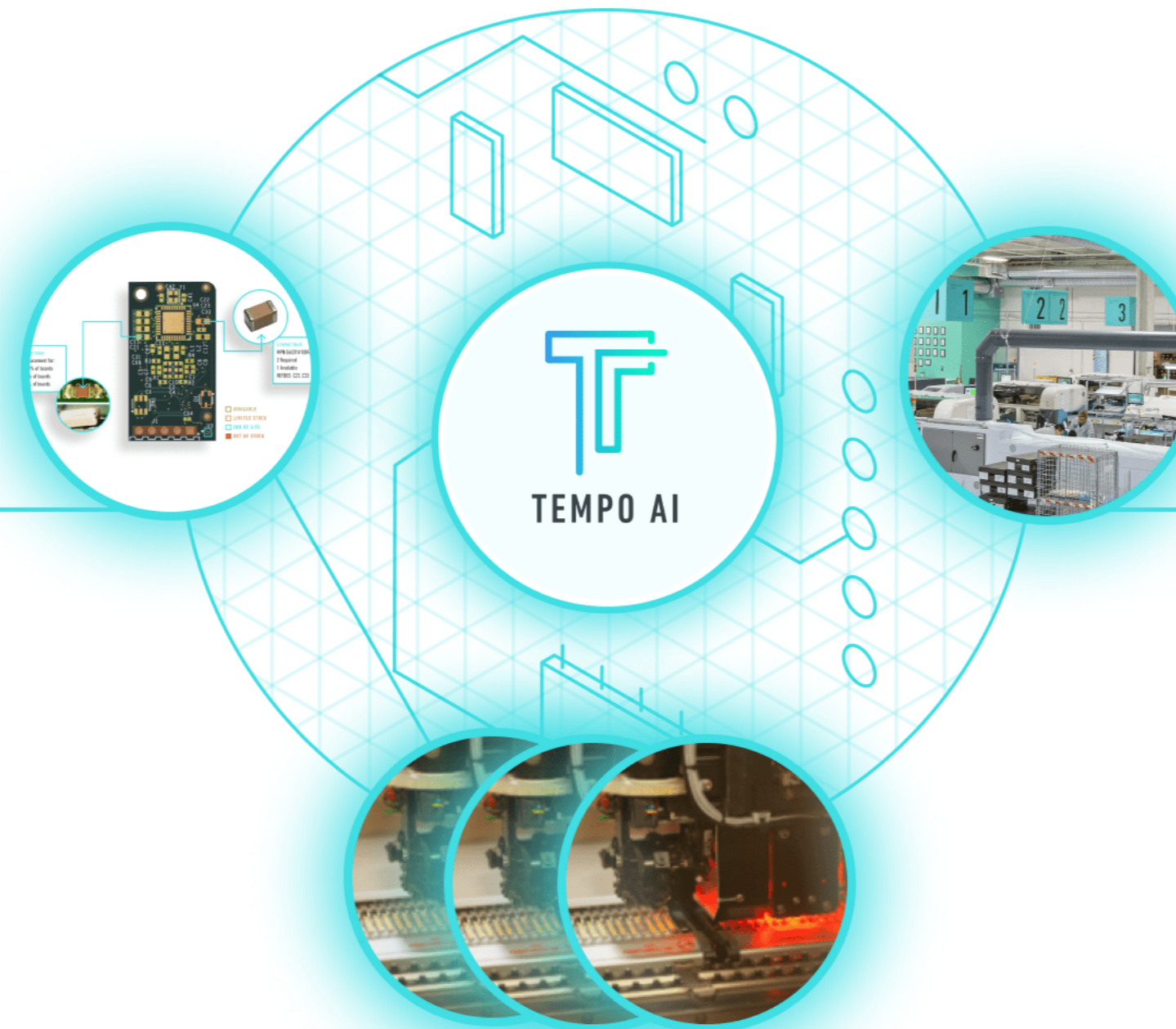

Increased speed and quality help acquired companies maintain and grow their customers

BACK-END MANUFACTURING SOFTWARE

Improved yield and streamlined processes increase margins



BOTTOM LINE BENEFITS TO ACQUIRED COMPANIES

Actionable Pipeline

Enables Rapid Execution of Further Tech-Enabled M&A

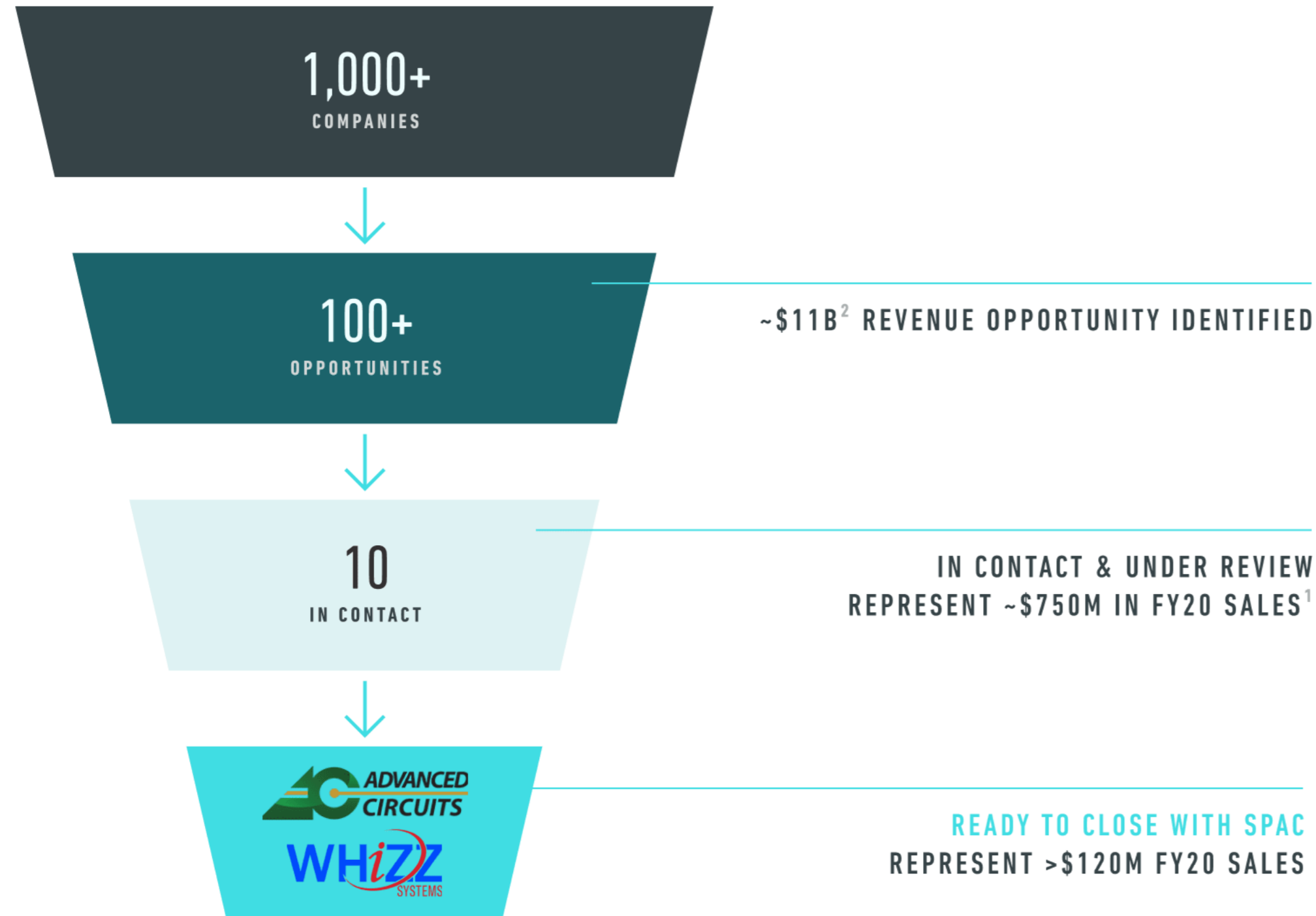

2025E REVENUE BRIDGE
\$ IN MILLIONS

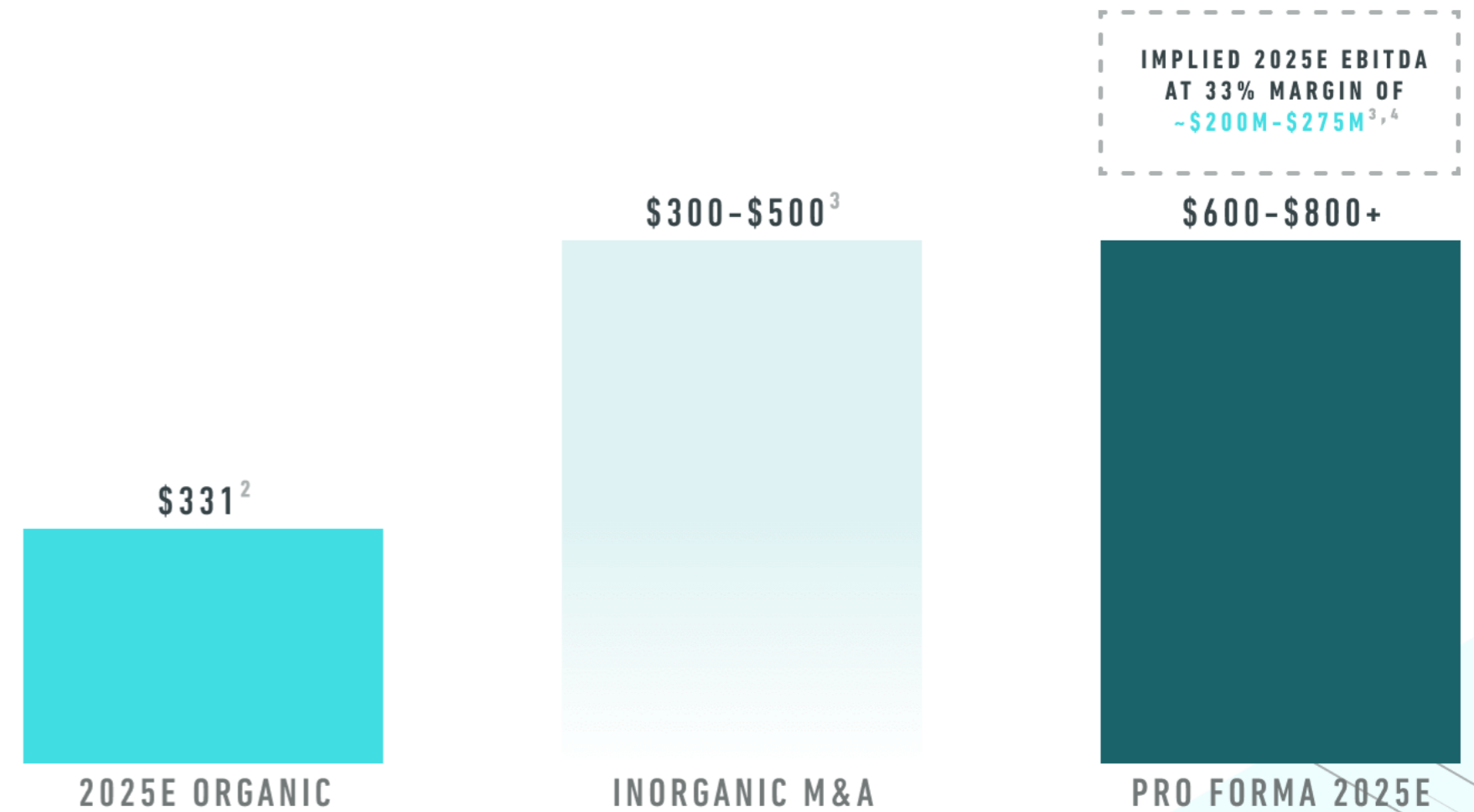

¹ Represents approximate FY20 revenue of the target companies on a standalone basis as communicated by such target or estimated by Tempo.

² Pro forma (PF) figures include the acquisitions of Compass AC Holdings, Inc. ("Advanced Circuits" or "AC") and Whizz Systems, Inc. ("Whizz Systems" or "Whizz") which are expected to close substantially concurrently with the SPAC business combination and exclude estimates of additional future acquisitions.

³ For illustrative purposes only.

⁴ EBITDA and EBITDA margin exclude certain non-cash charges such as depreciation & amortization, interest income & expense, stock-based compensation and other one-time or non-recurring charges. For a reconciliation of EBITDA margin to its most direct comparable GAAP measure, see the appendix.



Advanced Circuits Overview



Premier provider of **printed circuit board fabrication** and **prototype printed circuit board assembly**



A subsidiary of **Compass Diversified Holdings** (NYSE: CODI)



43% GAAP Gross Margin
vs. 20% US electronics manufacturing industry average¹



Broad customer base with **no customer >5% of FY20 sales**



Founded in **1989** and headquartered in **Aurora, Colorado**



440+ employees across **3 manufacturing facilities**
(Colorado, Arizona, and Minnesota)



\$88.1M

2020A REVENUE

END MARKETS



¹ IPC 2019 Annual Report and Forecast for the North American EMS Industry.

Whizz Systems Overview



Premier provider of **prototype and on-demand printed circuit board assembly**, as well as **engineering design services**



43% GAAP Gross Margin (46% 2020A Non-GAAP Gross Margin)¹ vs. 20% US electronics manufacturing industry average²



Trusted partner for **leading technology and semiconductor customers**



Founded in **1989** and headquartered in **Santa Clara, California**



120+ employees across **2 manufacturing facilities** (California and Malaysia)



\$35.7M

2020A REVENUE

END MARKETS



¹ Non-GAAP gross margin excludes certain non-recurring charges. For a reconciliation of non-GAAP measures, see the appendix.

² IPC 2019 Annual Report and Forecast for the North American EMS Industry.

STRICTLY PRIVATE & CONFIDENTIAL

Financials

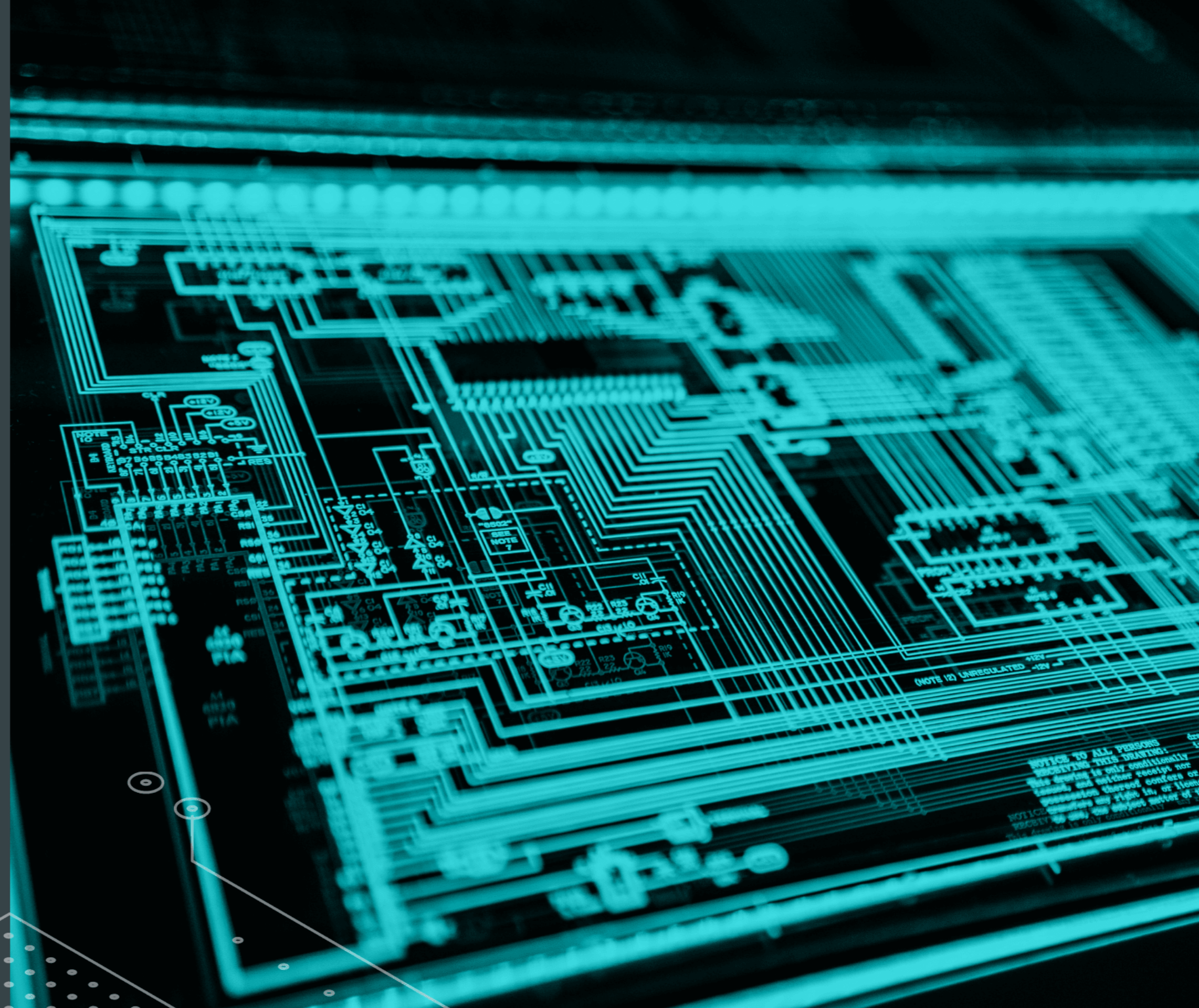

Detailed Transaction Overview

SOURCES AND USES (\$ IN MILLIONS)

SOURCES	\$ AMOUNT
ACE Cash in Trust	\$230
PIPE - Common Equity	82
PIPE - Convertible Debt	25
Structural Capital Senior Term Debt, net proceeds ¹	54
Shareholder Rollover Equity ^{2,3}	549
Total Sources	\$940
USES	\$ AMOUNT
<u>Equity Consideration</u>	
Equity to Shareholders ^{2,3}	\$549
<u>Cash at Close</u>	
Cash to AC & Whizz Shareholders	\$281
Transaction Expenses	45
Cash to Balance Sheet	65
Total Uses	\$940

Note: Assumes no redemption by public shareholders in connection with the transactions and Tempo's balance sheet as of June 30, 2021.

¹ Net of existing debt restructuring and associated make-whole premium.

² Includes Tempo, AC and Whizz shareholders. Excludes shares from a contemplated long-term incentive plan (LTIP) and employee stock purchase plan (ESPP).

³ Excludes earnout shares to be issued to Tempo, AC and Whizz shareholders. 7.5M earnout shares to be issued to existing Tempo shareholders subject to vest in three equal tranches at price thresholds of \$12.50, \$15.00 and \$18.00 per share, respectively; 2.4M earnout shares to be issued to AC shareholders subject to price threshold of \$12.50; maximum of 1.0M earnout shares to be issued to Whizz shareholders subject to price threshold of \$11.50 and certain net revenue and gross margin targets. Certain earnout provisions may be settled in cash or shares at Tempo's option.

⁴ Pro forma capitalization includes \$0.5M existing Tempo net debt balance as of June 30, 2021, \$57M New Structural Capital senior term debt (incremental principal, net of debt restructuring), \$25M new convertible debt, and \$65M incremental cash to balance sheet.

⁵ Assumes \$10.00 share price and no redemptions from public shareholders.

⁶ Reflects 46.1M Tempo existing equity holders shares, 23.0M SPAC IPO shares, 8.2M PIPE Investor shares, 7.0M AC equity holders shares, 5.8M SPAC sponsor shares, 1.8M Whizz equity holders shares.

⁷ Excludes participation in PIPE by existing Tempo shareholders and SPAC Sponsor.

PRO FORMA CAPITALIZATION^{2,3,4} (\$ IN MILLIONS, EXCEPT SHARE PRICE)

Share Price	\$10.00
PF Shares Outstanding	91.9
PF EQUITY VALUE	\$919
(+) PF Debt	115
(-) PF Cash	(98)
PRO FORMA FIRM VALUE	\$936

PRO FORMA OWNERSHIP^{5,6,7}

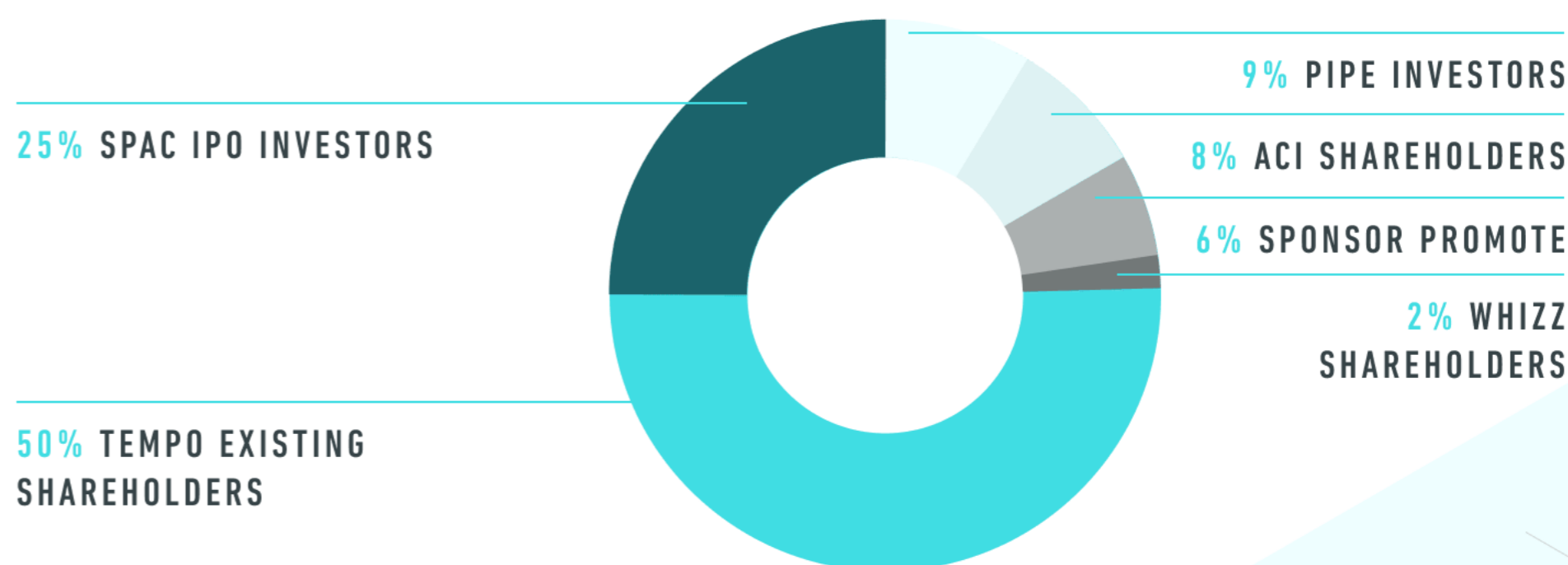

Strong Organic Growth Momentum

BUILDING SCALE WITH VERTICAL INTEGRATION AND PLATFORM ROLL-OUT

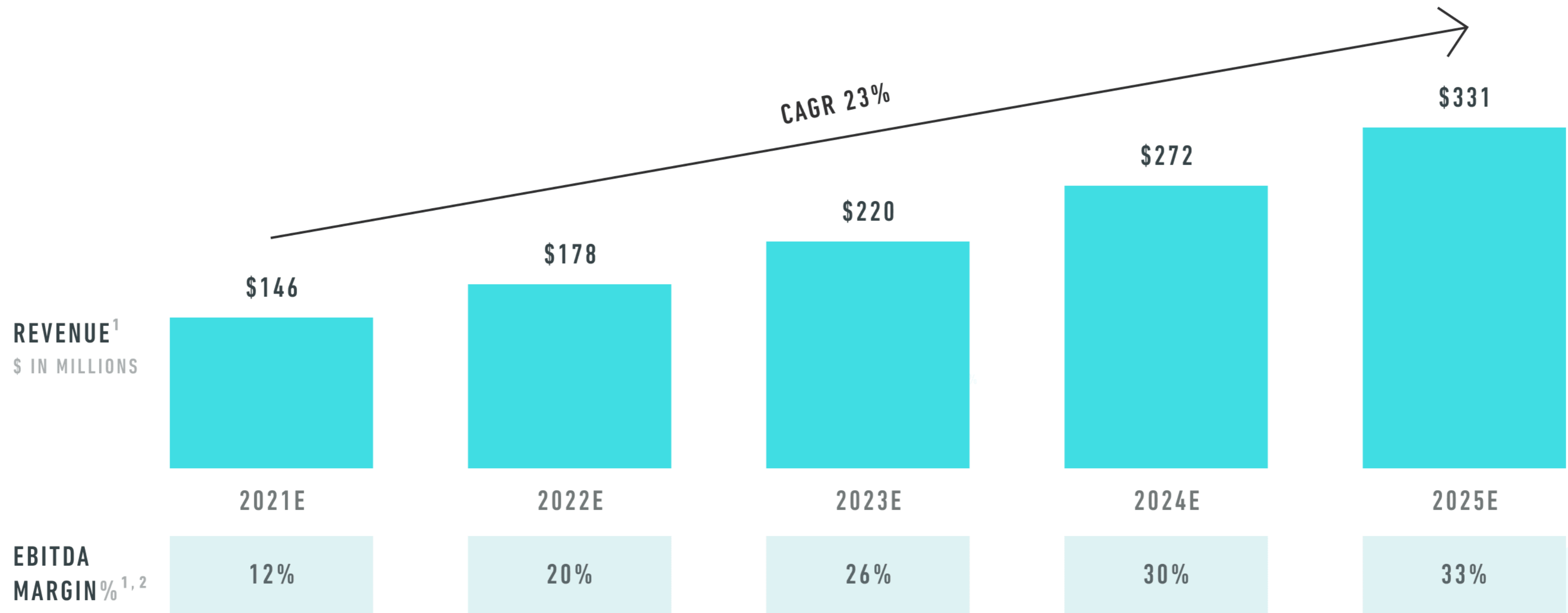

Source: Management Projections.

- 1 Pro forma (PF) figures include the acquisitions of Compass AC Holdings, Inc. ("Advanced Circuits" or "AC") and Whizz Systems, Inc. ("Whizz Systems" or "Whizz") which are expected to close substantially concurrently with the SPAC business combination and exclude estimates of additional future acquisitions.
- 2 EBITDA and EBITDA margin exclude certain non-cash charges such as depreciation & amortization, interest income & expense, stock-based compensation and other one-time or non-recurring charges. For a reconciliation of EBITDA margin to its most direct comparable GAAP measure, see the appendix.



Operating Leverage — Organic Non-GAAP Gross Margin

NON-GAAP COST OF GOODS SOLD (\$) AND NON-GAAP GROSS MARGIN (%)^{1, 2}

\$ IN MILLIONS

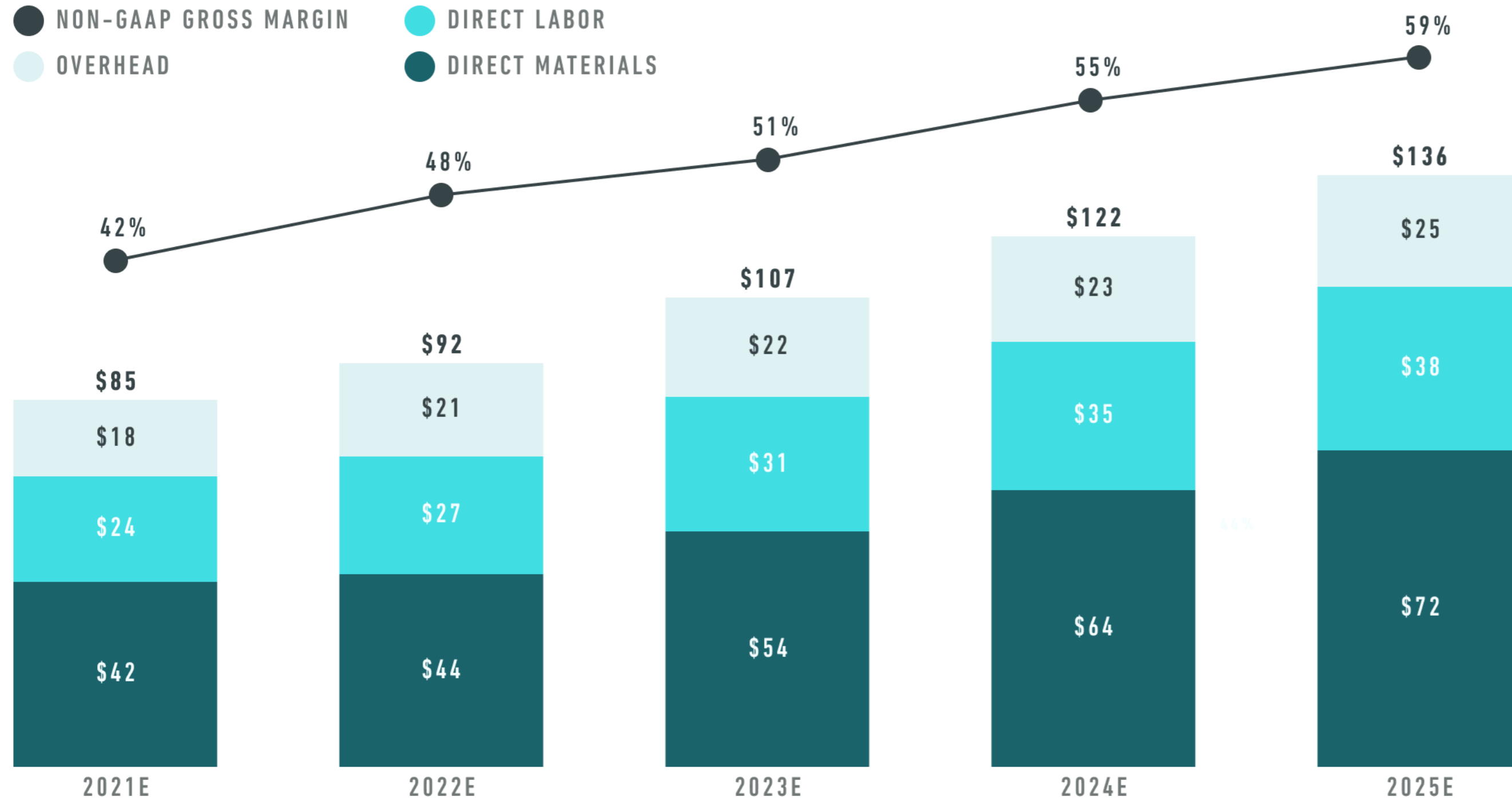

OVERHEAD

Improved overhead costs with combination synergies and increased economies of scale

DIRECT LABOR AND DIRECT MATERIALS

Lower labor costs and better yields from implementation and continued development of Tempo's platform (software and equipment)

Vertical integration synergies realized by insourcing PCB spend

Source: Management Projections.

¹ Pro forma (PF) figures include the acquisitions of Compass AC Holdings, Inc. ("Advanced Circuits" or "AC") and Whizz Systems, Inc. ("Whizz Systems" or "Whizz") which are expected to close substantially concurrently with the SPAC business combination and exclude estimates of additional future acquisitions.

² Non-GAAP Cost of Goods Sold and non-GAAP gross margin exclude stock-based compensation and non-recurring transaction related expenses incurred and forecasted in 2021.



Operating Leverage — Organic Non-GAAP Operating Expenses

NON-GAAP OPERATING EXPENSE^{1, 2}

\$ IN MILLIONS

- % OF ORGANIC REVENUE
- RESEARCH & DEVELOPMENT
- SELLING, GENERAL & ADMINISTRATIVE

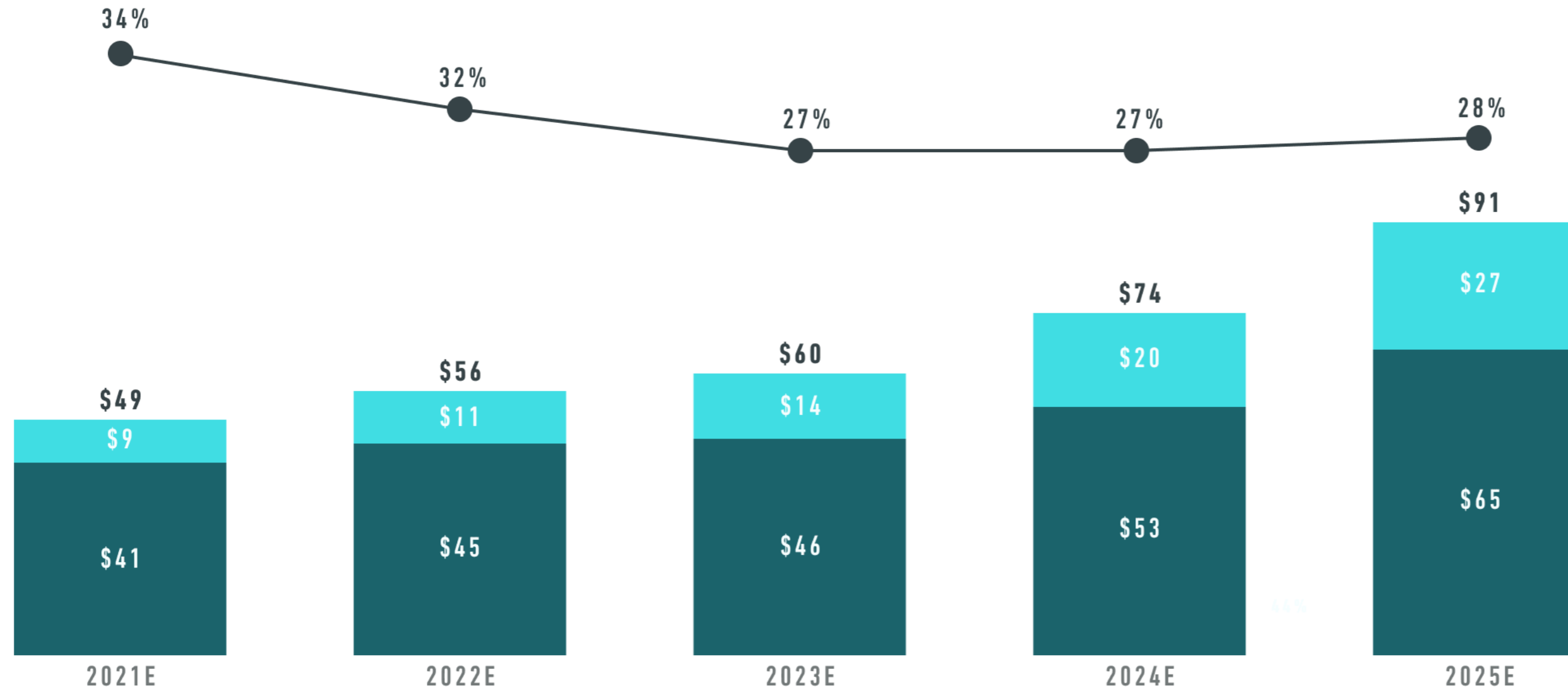

RESEARCH & DEVELOPMENT

Continued investment in Tempo platform development and rollout

SELLING, GENERAL & ADMINISTRATIVE

Increased sales force and growing national marketing efforts as client base grows

Benefits of scale provide increasing operating leverage



Source: Management Projections.

- Pro forma (PF) figures include the acquisitions of Compass AC Holdings, Inc. ("Advanced Circuits" or "AC") and Whizz Systems, Inc. ("Whizz Systems" or "Whizz") which are expected to close substantially concurrently with the SPAC business combination and exclude estimates of additional future acquisitions.
- Non-GAAP operating expenses exclude stock-based compensation and non-recurring transaction related expenses incurred and forecasted in 2021.

Organic Non-GAAP Operating Margin Bridge

NON-GAAP OPERATING PROFIT (\$) AND NON-GAAP OPERATING MARGIN (%)^{1,2} BRIDGE 2021E – 2025E

\$ IN MILLIONS

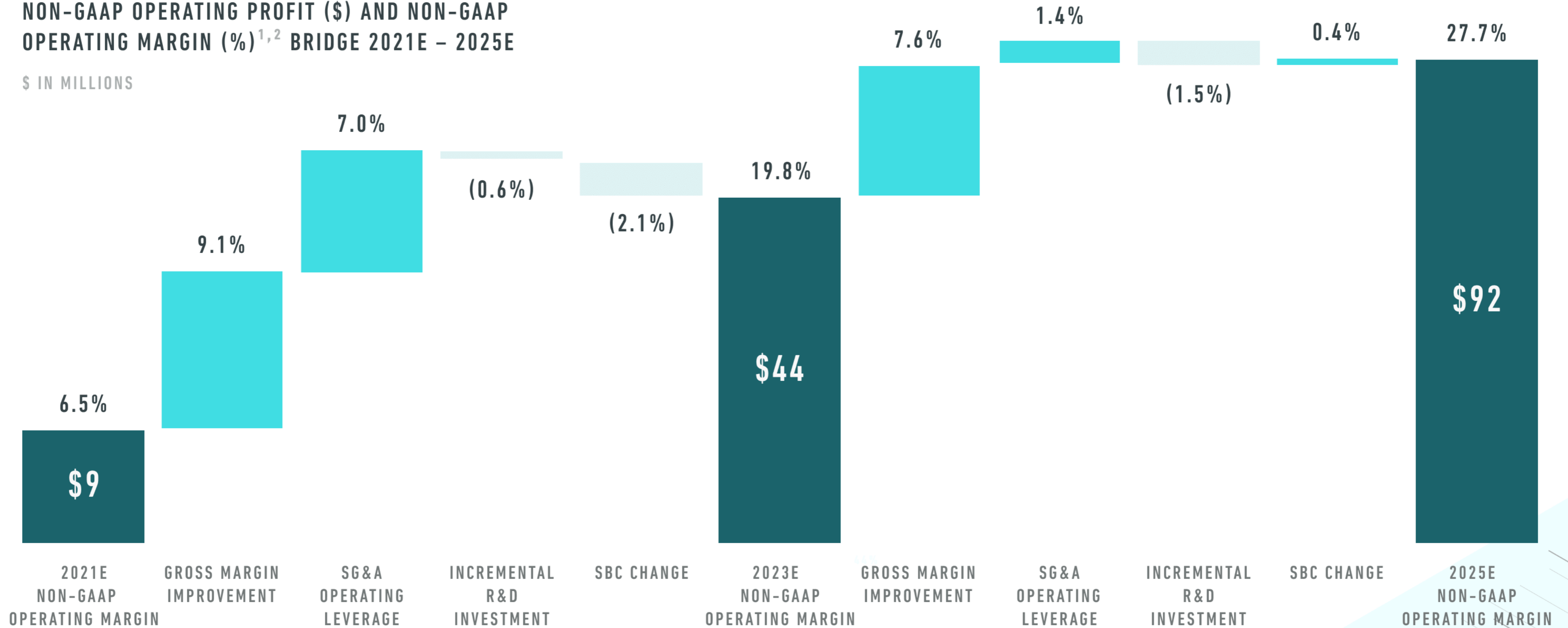

Source: Management Projections.

- 1 Pro Forma (PF) figures include the acquisitions of Compass AC Holdings, Inc. (“Advanced Circuits” or “AC”) and Whizz Systems, Inc. (“Whizz Systems” or “Whizz”) which are expected to close substantially concurrently with the SPAC business combination and exclude estimates of additional future acquisitions.
- 2 Non-GAAP operating profit and non-GAAP operating margin exclude non-recurring transaction related expenses incurred and forecasted in 2021.



Overview of Organic Financial Performance¹

REVENUE(\$)¹ AND GROWTH RATE(%)

\$ IN MILLIONS

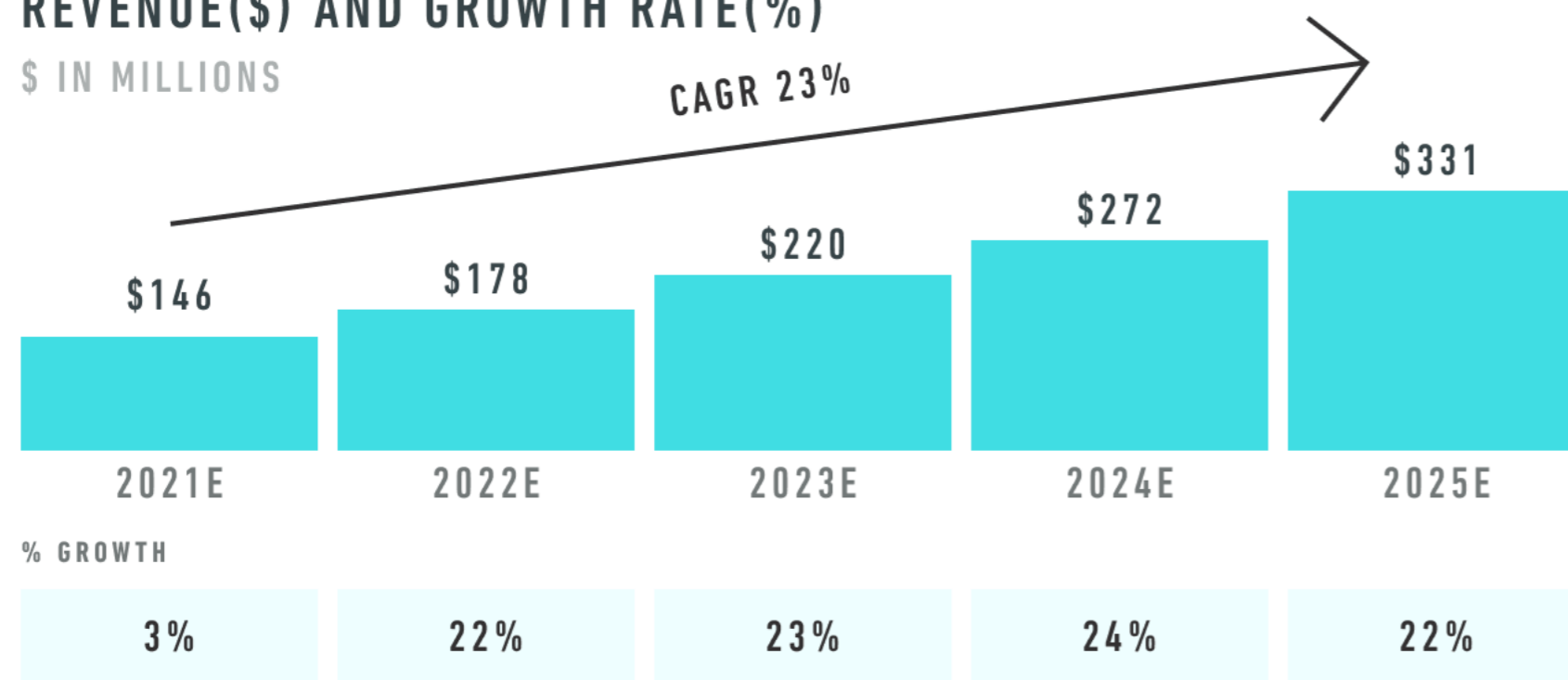

EBITDA(\$)² AND EBITDA MARGIN(%)²

\$ IN MILLIONS

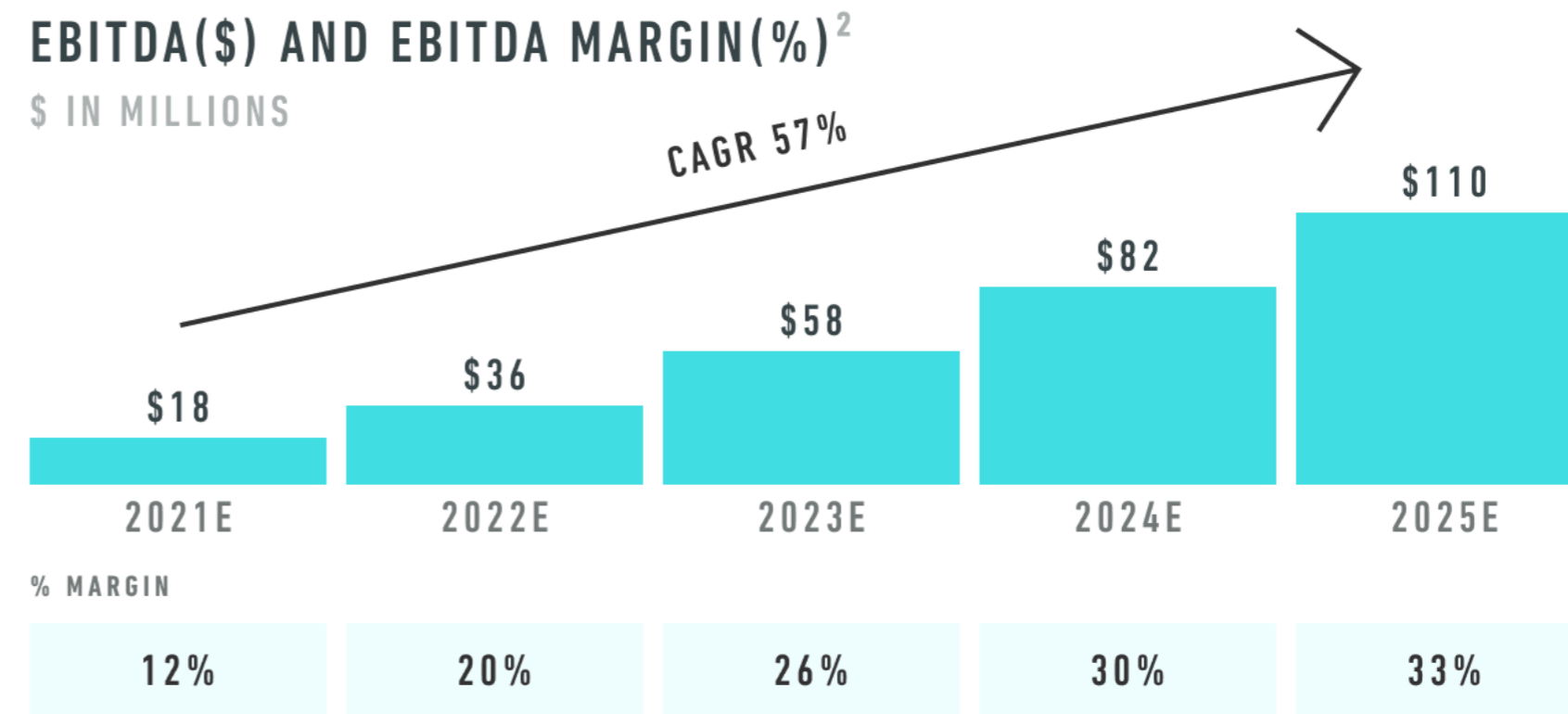

NON-GAAP GROSS PROFIT(\$)³ AND GROSS MARGIN (%)³

\$ IN MILLIONS

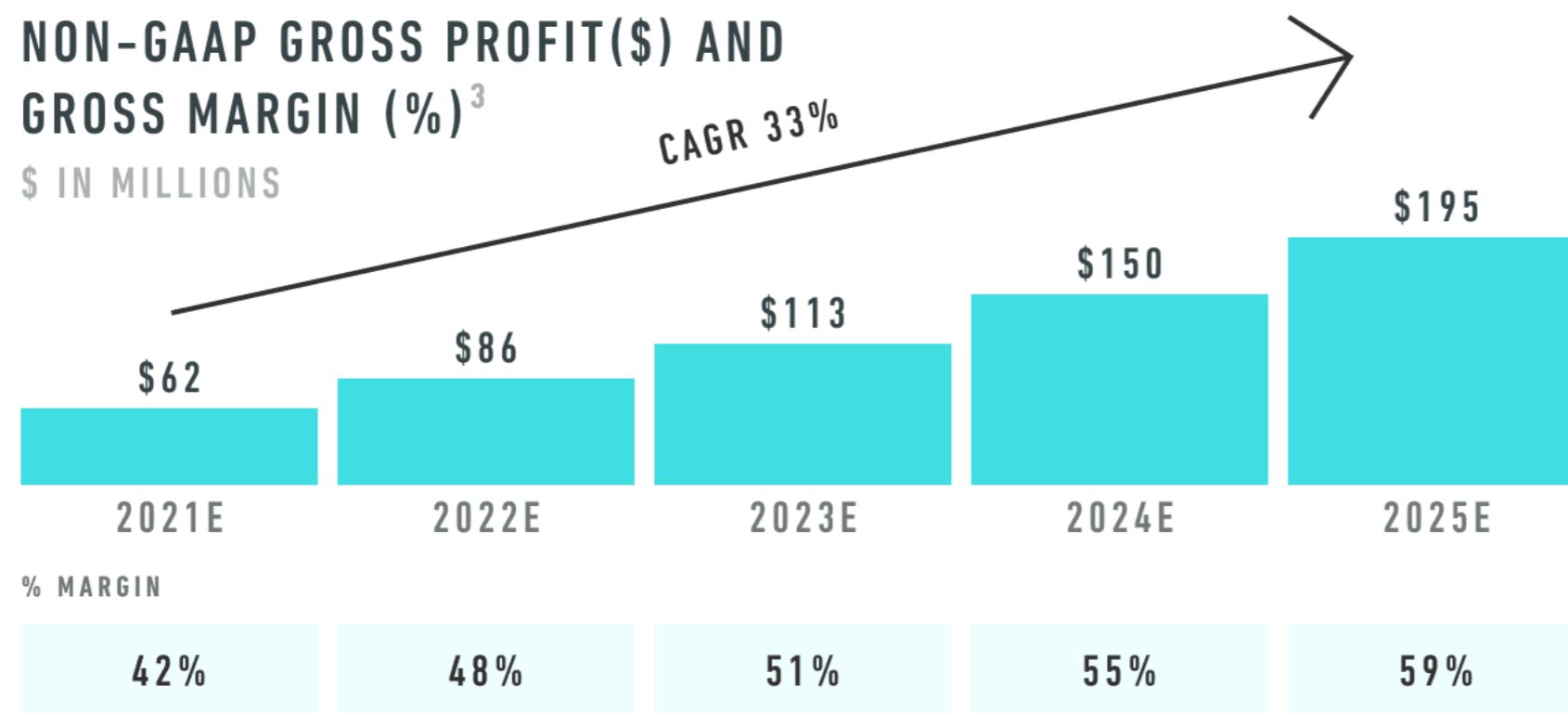

UNLEVERED FREE CASH FLOW(\$)^{4,5} AND UFCF CONVERSION(%)^{4,5}

\$ IN MILLIONS

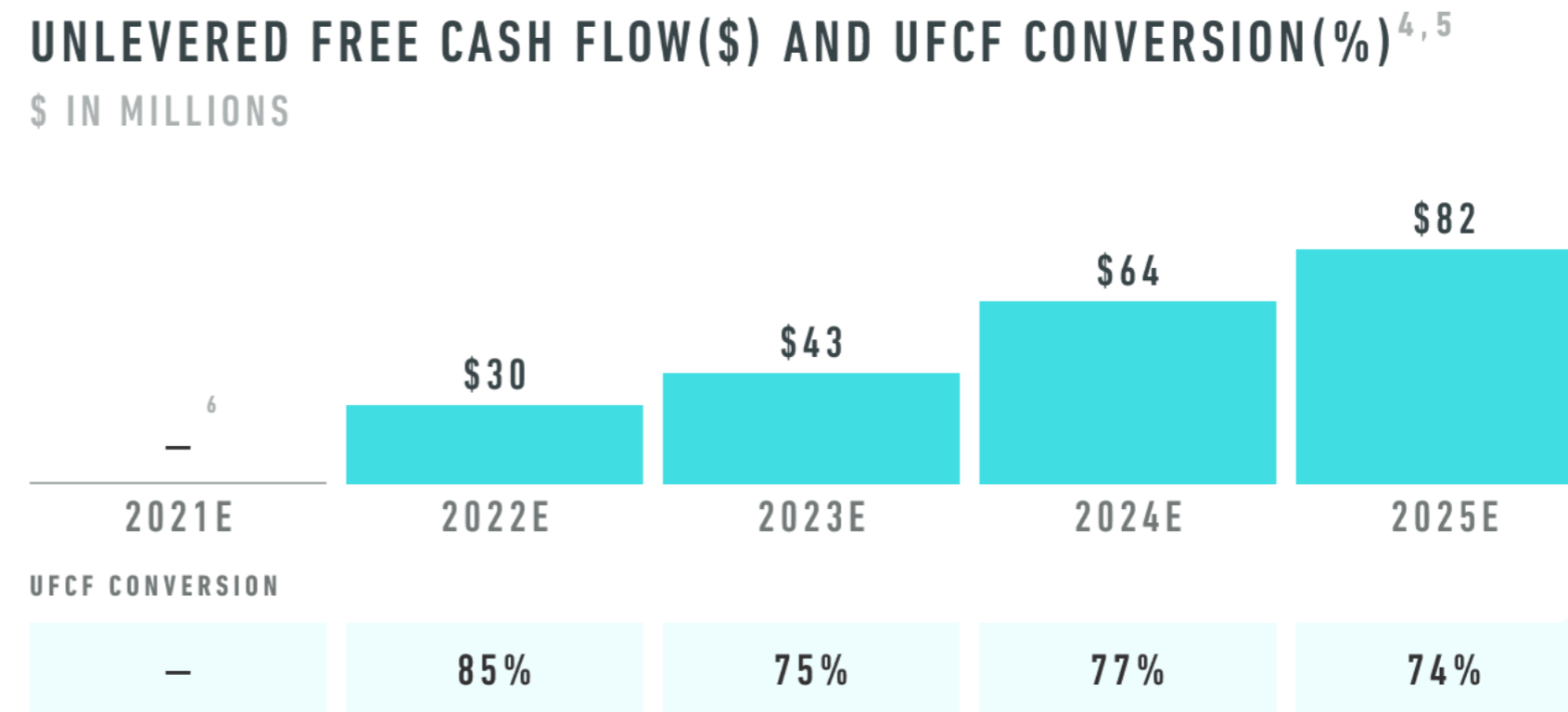

Source: Management Projections.

¹ Pro forma (PF) figures include the acquisitions of Compass AC Holdings, Inc. ("Advanced Circuits" or "AC") and Whizz Systems, Inc. ("Whizz Systems" or "Whizz") which are expected to close substantially concurrently with the SPAC business combination and exclude estimates of additional future acquisitions.

² EBITDA and EBITDA margin exclude certain non-cash charges such as depreciation & amortization, interest income & expense, stock-based compensation and other one-time or non-recurring charges. For a reconciliation of EBITDA and EBITDA margin to their most direct comparable GAAP measures, see the appendix. 2021 EBITDA excludes non-recurring transaction related expenses.

³ Non-GAAP gross profit and non-GAAP gross margin exclude non-recurring transaction related expenses incurred and forecasted in 2021.

⁴ Unlevered Free Cash Flow (UFCF) is defined as EBITDA less capital expenditures, cash taxes, and change in working capital. UFCF Conversion is defined as Unlevered Free cash Flow as a percentage of EBITDA.

⁵ These projections assume approximately \$10M of annual capital expenditures.

⁶ Assumes Tempo's acquisition of Advanced Circuits and Whizz Systems closes December 31, 2021.



Valuation



Tempo Highlights: Defining the Opportunity vs. Peer Groups

- 1 Differentiated tech-enabled focus on fragmented \$290B electronics prototyping and on-demand production market¹
- 2 Proprietary software platform, with AI that learns from every order, redefines the customer journey and accelerates time-to-market
- 3 High growth, high margin business
- 4 Expected upside from further inorganic growth
- 5 Broad customer base and track record of customer expansion

REVENUE² '21E – '23E



EBITDA^{2,3} '21E – '23E

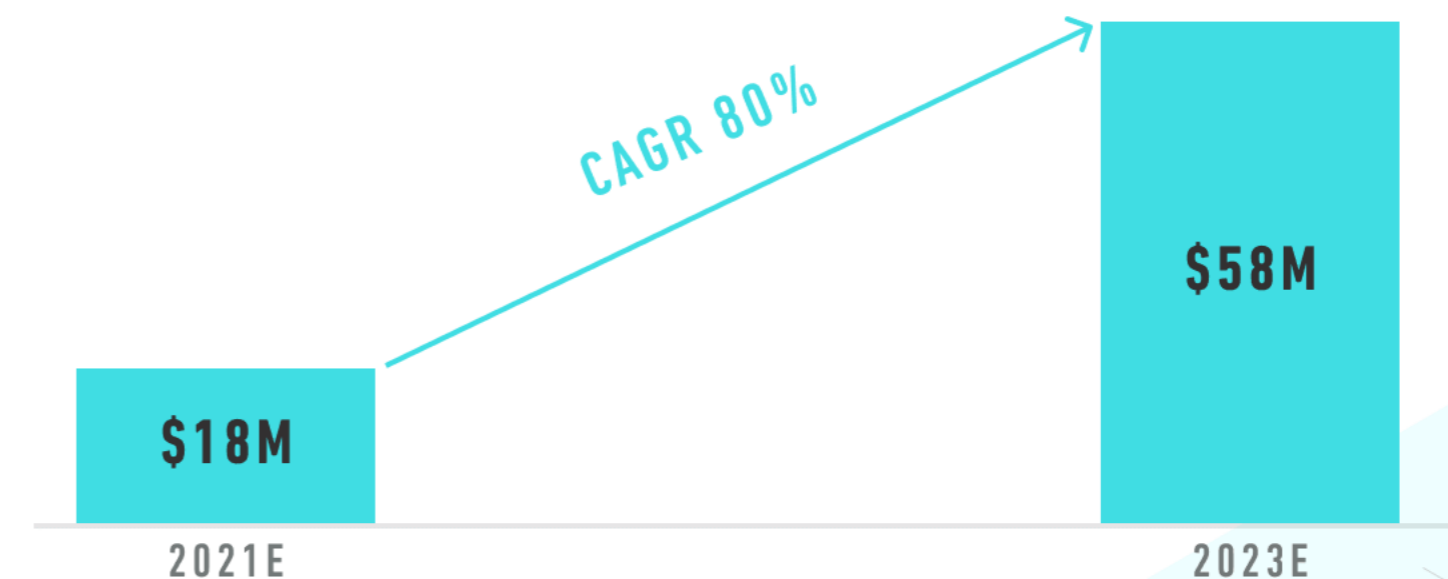

Source: Management Projections.

¹ IPC 2012-2013, 2018, 2019 Annual Reports and Forecasts for the North American EMS Industry; company estimates.

² Pro forma (PF) figures include the acquisitions of Compass AC Holdings, Inc. ("Advanced Circuits" or "AC") and Whizz Systems, Inc. ("Whizz Systems" or "Whizz") which are expected to close substantially concurrently with the SPAC business combination and exclude estimates of additional future acquisitions.

³ EBITDA and EBITDA margin exclude certain non-cash charges such as depreciation & amortization, interest income & expense, stock-based compensation and other one-time or non-recurring charges. For a reconciliation of EBITDA and EBITDA margin to their most direct comparable GAAP measures, see the appendix. 2021 EBITDA excludes non-recurring transaction related expenses.



Tempo is at the Intersection of Multiple Growth Segments

DIGITAL MANUFACTURING



- Software-enabled manufacturing across a range of technologies and end markets

MEDIAN TOTAL ADDRESSABLE MARKET: \$115B¹

ADVANCED MANUFACTURING



- Hardware-centric technology platforms disrupting large industrial end markets

MEDIAN TOTAL ADDRESSABLE MARKET: \$17B¹

SOFTWARE



- Scaled EDA and PLM software players
- Exposed to same or similar end market trends

MEDIAN TOTAL ADDRESSABLE MARKET: \$7B¹

TEMPO TOTAL ADDRESSABLE MARKET: \$290B²



¹ Companies' filings. Calculated as median for the group.
² IPC 2012-2013, 2018, 2019 Annual Reports and Forecasts for the North American EMS Industry; company estimates.

Tempo's Combination of Margins and Growth is Unique Amongst its Peers

2021E – 2023E REVENUE CAGR VS 2023E EBITDA MARGIN

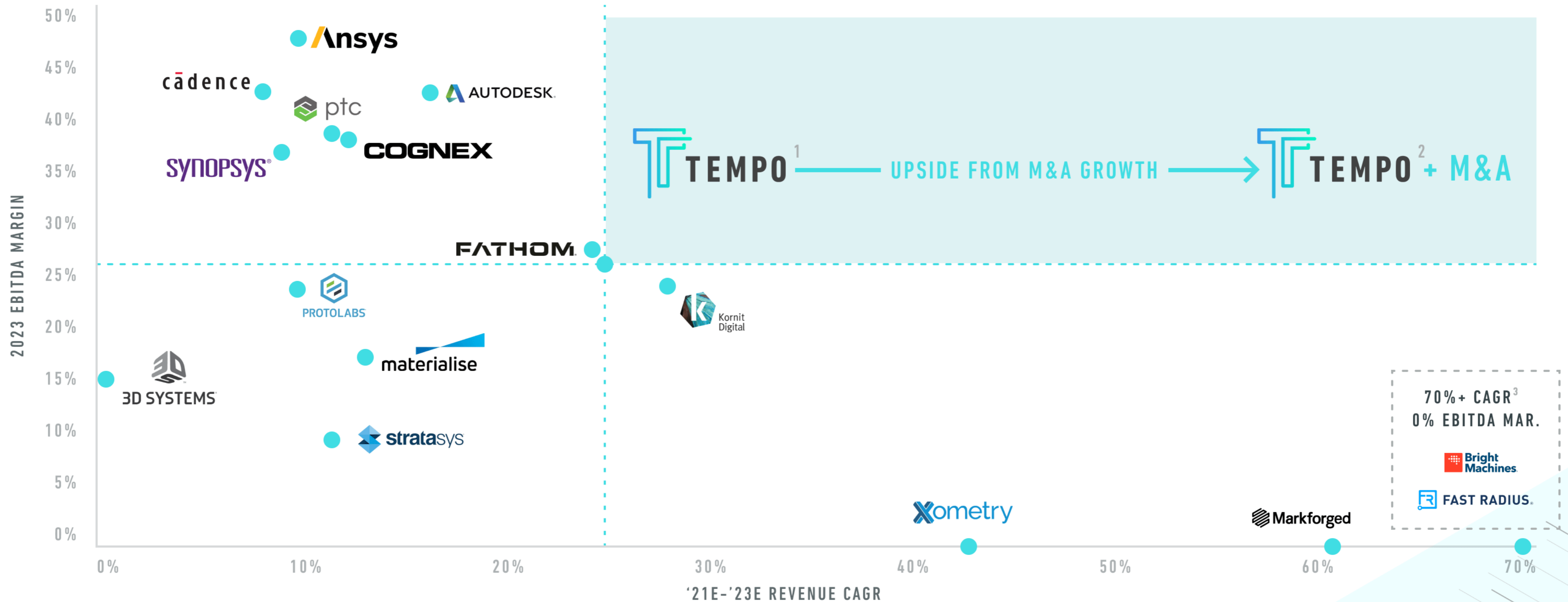

Source: Investor Presentations and FactSet. Market date of October 8, 2021.

- 1 Pro forma (PF) figures include the acquisitions of Compass AC Holdings, Inc. ("Advanced Circuits" or "AC") and Whizz Systems, Inc. ("Whizz Systems" or "Whizz") which are expected to close substantially concurrently with the SPAC business combination and exclude estimates of additional future acquisitions.
- 2 Tempo + M&A includes the acquisitions of Compass AC Holdings, Inc. ("Advanced Circuits" or "AC") and Whizz Systems, Inc. ("Whizz Systems" or "Whizz") which are expected to close substantially concurrently with the SPAC business combination and other potential acquisitions.
- 3 Fast Radius and Bright Machines have projected '21E-'23E Revenue CAGR of 214% and 74% respectively. Projected 2023 EBITDA margins are below 0%.



Tempo vs. Comparable Companies – Revenue Multiples

DIGITAL MANUFACTURING

ADVANCED MANUFACTURING

SOFTWARE²

FIRM VALUE / 2023E REVENUE

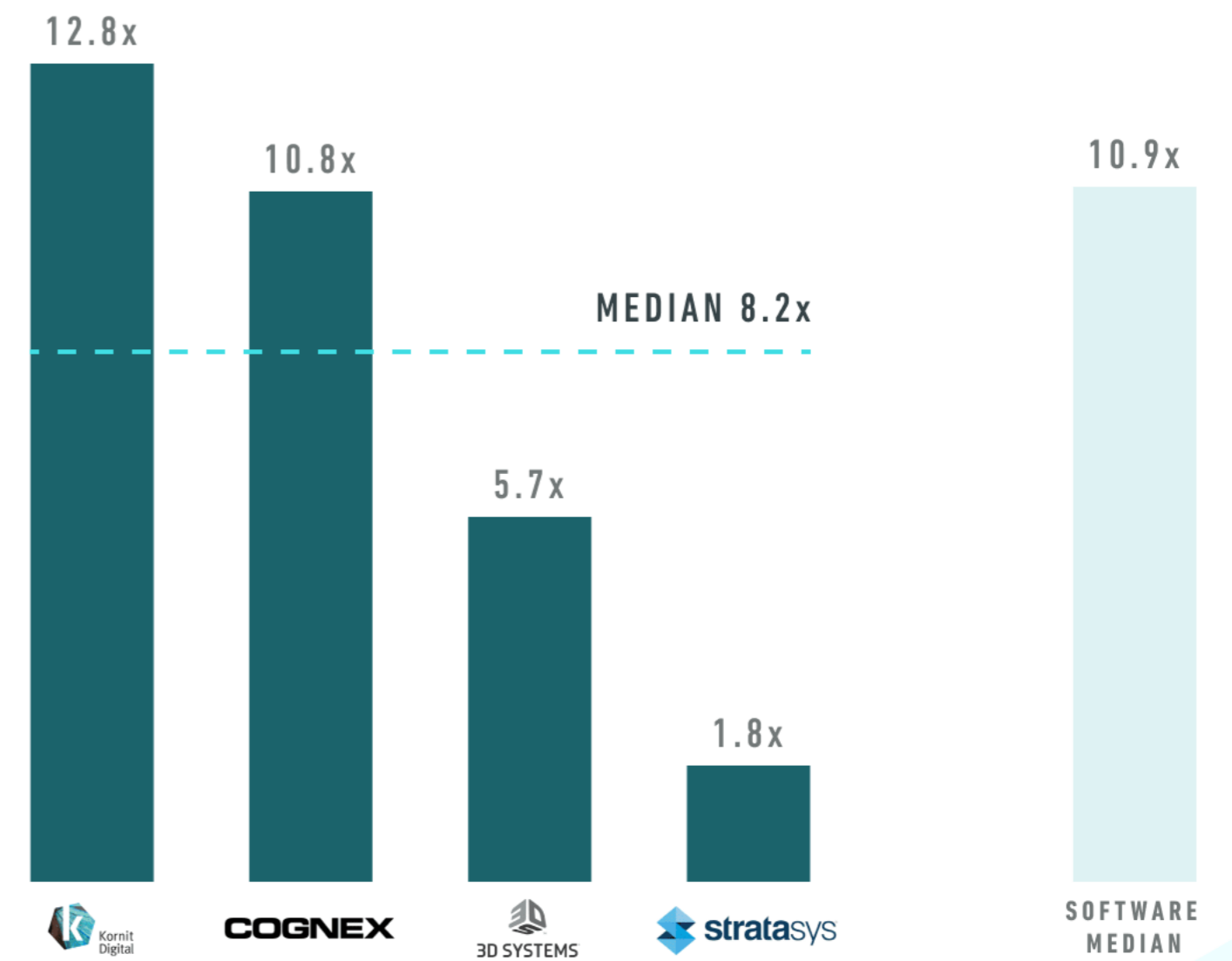
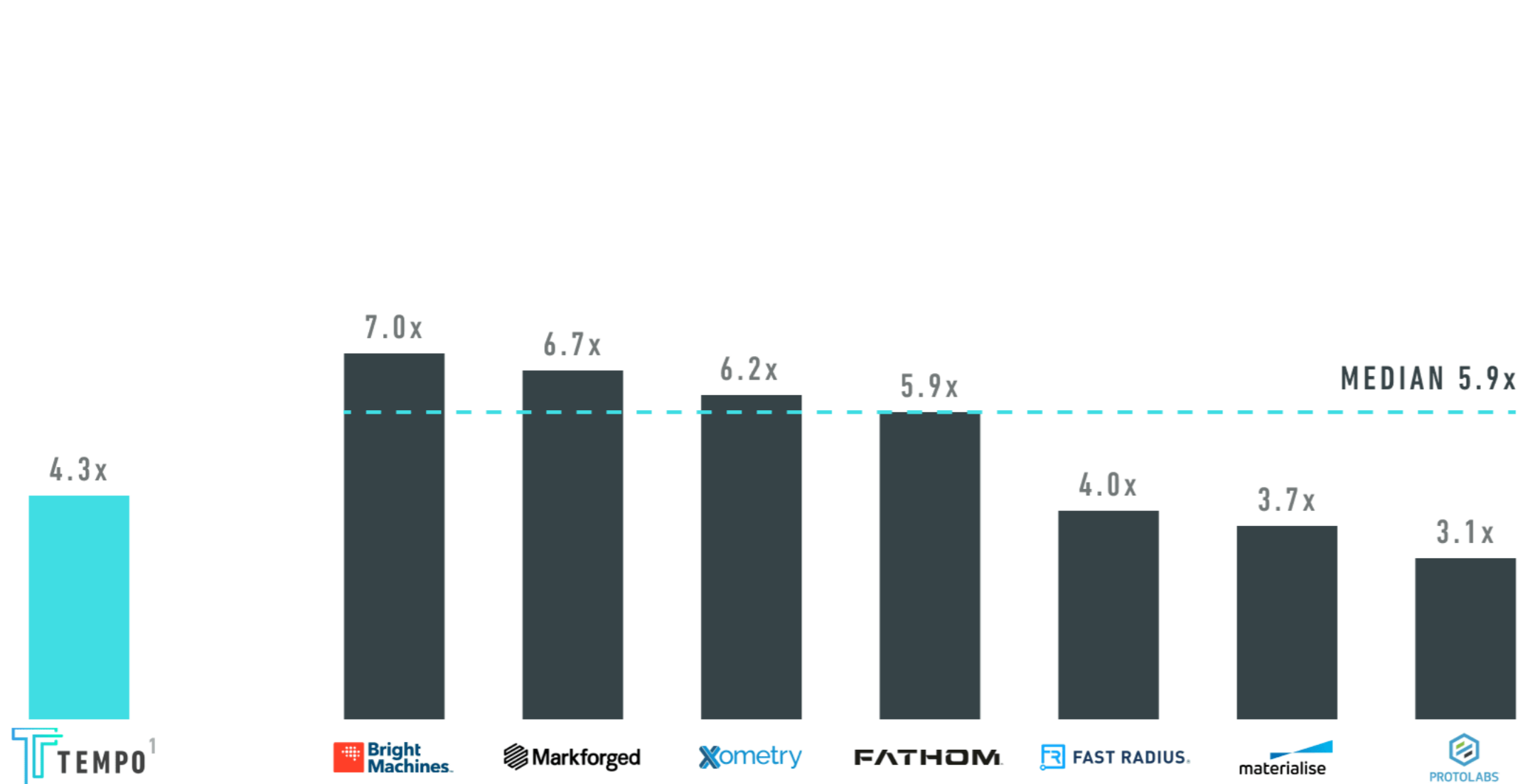

FIRM VALUE / 2022E REVENUE



Source: Investor Presentations and FactSet. Market date as of October 8, 2021.

¹ Pro forma (PF) figures include the acquisitions of Compass AC Holdings, Inc. ("Advanced Circuits" or "AC") and Whizz Systems, Inc. ("Whizz Systems" or "Whizz") which are expected to close substantially concurrently with the SPAC business combination and exclude estimates of additional future acquisitions. Excludes \$75M Tempo earnout.

² Software peers include: Ansys, Autodesk, Cadence, PTC, and Synopsys.



Tempo vs. Comparable Companies – EBITDA Multiples

DIGITAL MANUFACTURING

ADVANCED MANUFACTURING

SOFTWARE²

FIRM VALUE / 2023E EBITDA

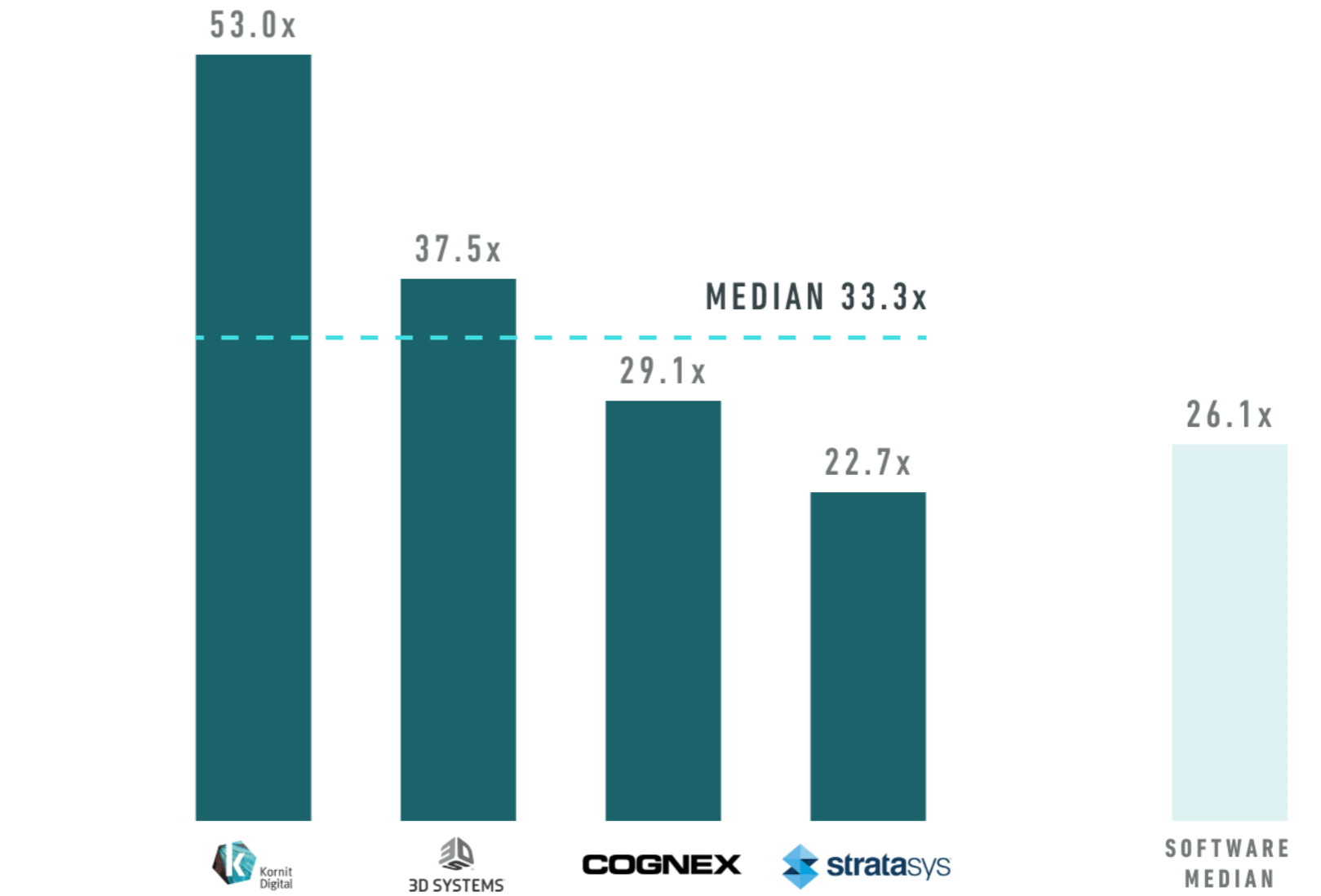
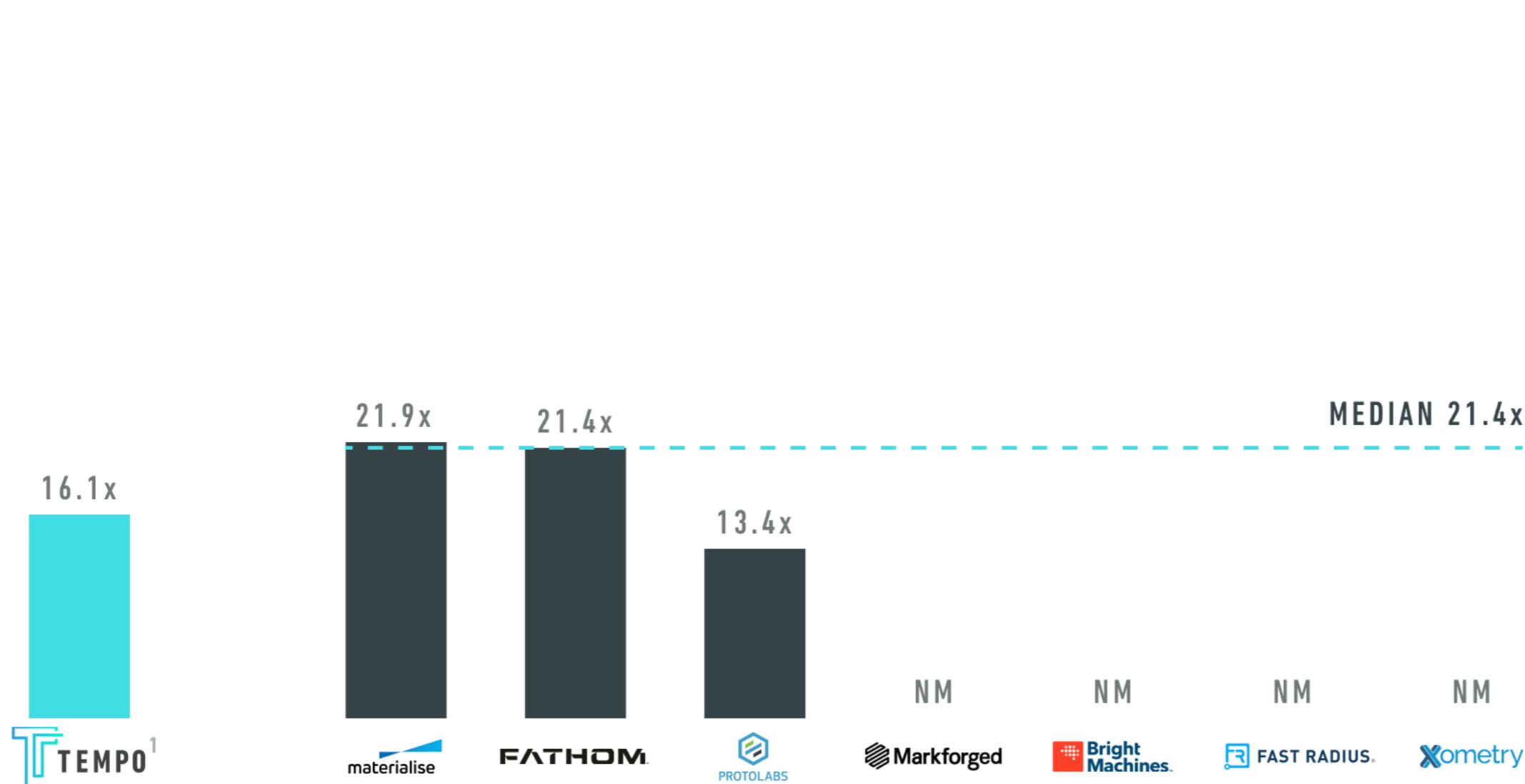

FIRM VALUE / 2022E EBITDA

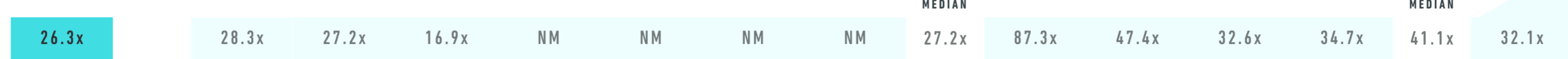

Source: Investor Presentations and FactSet. Market date as of October 8, 2021.

¹ Pro forma (PF) figures include the acquisitions of Compass AC Holdings, Inc. (“Advanced Circuits” or “AC”) and Whizz Systems, Inc. (“Whizz Systems” or “Whizz”) which are expected to close substantially concurrently with the SPAC business combination and exclude estimates of additional future acquisitions. Excludes \$75M Tempo earnout.

² Software peers include: Ansys, Autodesk, Cadence, PTC, and Synopsys.



Transaction Overview

BUSINESS OVERVIEW	<ul style="list-style-type: none">• Software-accelerated electronics manufacturer leveraged by many of the world's most innovative companies to get products to market faster• In connection with its business combination with ACE, Tempo expects to acquire two targets, Advanced Circuits and Whizz Systems, creating a vertically integrated, scaled platform poised to capture a fragmented \$290B market¹
CAPITAL STRUCTURE	<ul style="list-style-type: none">• Established high margin financial profile with, on a pro forma basis², EBITDA margin³ of 12% in 2021E, and growing to 20% in 2022E• Post transaction, ~\$65M⁴ incremental cash on balance sheet to accelerate growth
VALUATION	<ul style="list-style-type: none">• \$936M pro forma enterprise value• Attractively-valued entry multiple for a high growth business in a massive market
CASH PROCEEDS	<ul style="list-style-type: none">• ACE has \$230M of cash in trust⁴• PIPE and new debt raise of \$161M from premier institutional investors and technology lenders including ACE Equity Partners (an affiliate of ACE's sponsor), Point72 Ventures Investments, Firsthand Funds, Lux Ventures, Structural Capital, and SQN Venture Partners

¹ IPC 2012-2013, 2018, 2019 Annual Reports and Forecasts for the North American EMS Industry; company estimates.

² Pro forma (PF) figures include the acquisitions of Compass AC Holdings, Inc. ("Advanced Circuits" or "AC") and Whizz Systems, Inc. ("Whizz Systems" or "Whizz") which are expected to close substantially concurrently with the SPAC business combination and exclude estimates of additional future acquisitions.

³ EBITDA and EBITDA margin exclude certain non-cash charges such as depreciation & amortization, interest income & expense, stock-based compensation and other one-time or non-recurring charges. For a reconciliation of EBITDA margin to its most direct comparable GAAP measure, see the appendix.

⁴ Assumes no redemptions by ACE existing shareholders. The trust account includes approximately \$8.1M in deferred underwriting fees that will be payable to the underwriters of ACE's initial public offering in the event that the business combination is completed.



Appendix

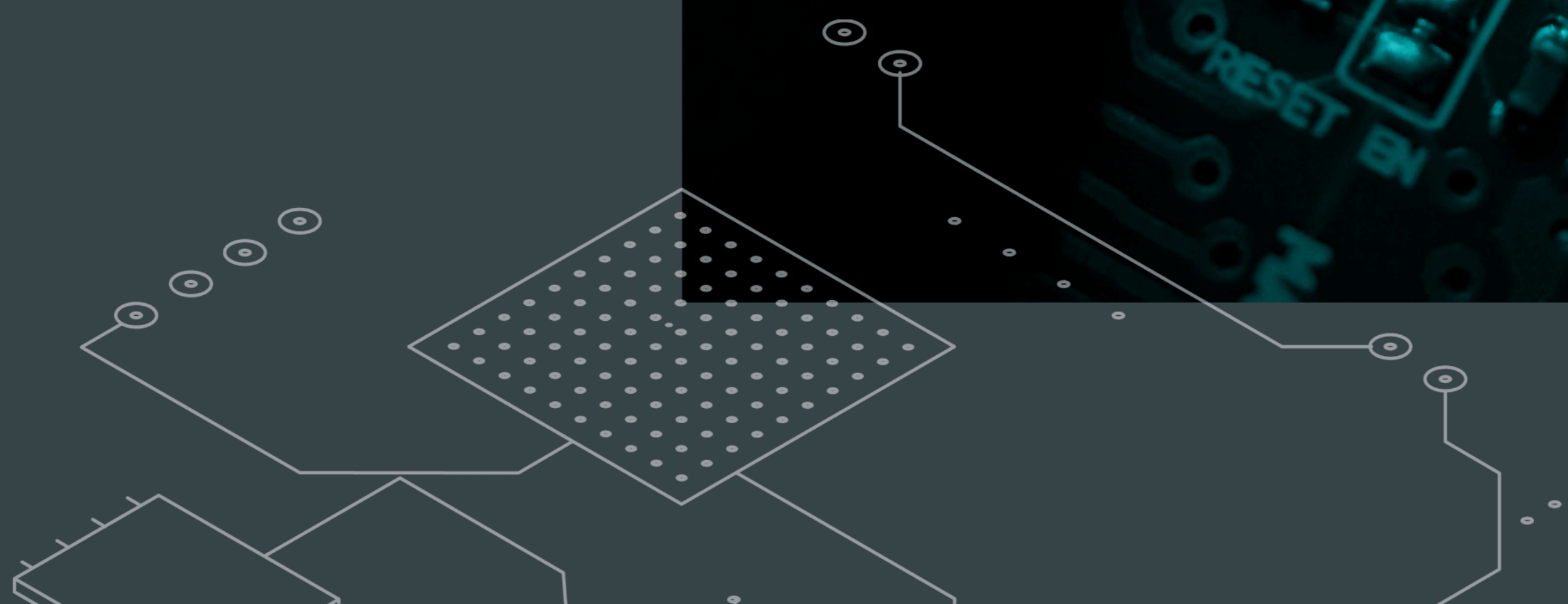
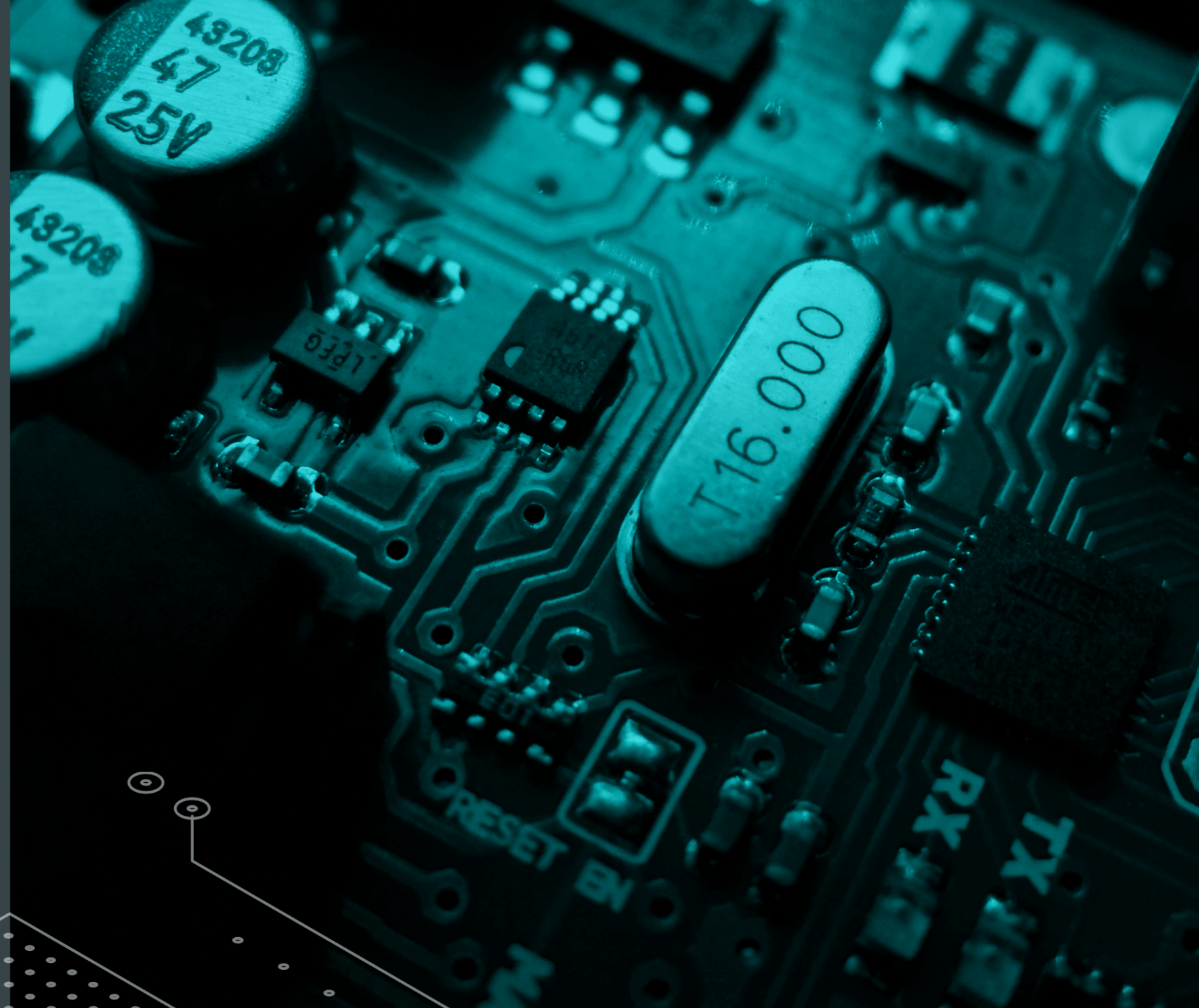

Proforma Financial Summary¹

\$ IN MILLIONS

	YEAR ENDED DECEMBER 31							CAGR
	2019A	2020A	2021E	2022E	2023E	2024E	2025E	2021-2025E
REVENUE	\$145.3	\$142.3	\$146.3	\$178.4	\$220.1	\$271.9	\$331.0	22.6%
GROWTH %		(2.1%)	2.8%	21.9%	23.4%	23.6%	21.7%	
(-) COST OF GOODS SOLD	(85.8)	(83.4)	(84.6)	(92.5)	(107.3)	(121.6)	(136.2)	
NON-GAAP GROSS PROFIT²	\$59.5	\$58.9	\$61.7	\$85.9	\$112.8	\$150.3	\$194.8	33.3%
NON-GAAP GROSS MARGIN	40.9%	41.4%	42.2%	48.2%	51.3%	55.3%	58.9%	
(-) OPERATING EXPENSES	(44.7)	(42.8)	(52.3)	(62.7)	(69.2)	(84.7)	(103.0)	
NON-GAAP OPERATING PROFIT³	\$14.7	\$16.1	\$9.5	\$23.2	\$43.6	\$65.6	\$91.8	76.5%
NON-GAAP OPERATING MARGIN %	10.1%	11.3%	6.5%	13.0%	19.8%	24.1%	27.7%	
(+) DEPRECIATION & AMORTIZATION	4.9	5.8	5.7	5.9	5.7	5.8	6.4	
(+) STOCK-BASED COMPENSATION	1.3	1.8	2.8	6.4	8.7	10.8	11.9	
EBITDA⁴	\$20.9	\$23.6	\$18.0	\$35.6	\$58.1	\$82.3	\$110.1	57.4%
EBITDA MARGIN %	14.4%	16.6%	12.3%	20.0%	26.4%	30.3%	33.3%	
(-) CAPITAL EXPENDITURES	(12.6)	(3.1)	(2.6)	(9.6)	(9.9)	(9.8)	(6.4)	
(-) CASH TAXES				(1.0)	(1.8)	(5.7)	(19.3)	
(-) CHANGE IN NWC				5.3	(2.9)	(3.1)	(2.8)	
UNLEVERED FREE CASH FLOW (FCF)				\$30.3	\$43.4	\$63.7	\$81.6	NM
UFCF CONVERSION %				85.2%	74.8%	77.4%	74.1%	

Source: Management Projections.

¹ Pro forma (PF) figures include the acquisitions of Compass AC Holdings, Inc. ("Advanced Circuits" or "AC") and Whizz Systems, Inc. ("Whizz Systems" or "Whizz") which are expected to close substantially concurrently with the SPAC business combination and exclude estimates of additional future acquisitions.

² Non-GAAP gross profit and non-GAAP gross margin exclude \$0.3M (FY19) and \$1.2M (FY20) of certain one-time non-recurring charges.

³ Non-GAAP operating profit and operating margin exclude \$0.8M (FY19) and \$6.0M (FY20) of certain one-time or non-recurring charges in 2019 and 2020. For a description of these items, see the Reconciliation to EBITDA in this appendix.

⁴ EBITDA and EBITDA margin exclude certain non-cash charges such as depreciation & amortization, interest income & expense, stock-based compensation and other one-time or non-recurring charges. For a reconciliation of EBITDA and EBITDA margin to their most direct comparable GAAP measures, see the Reconciliation to EBITDA in this appendix.



Reconciliation to EBITDA

UNAUDITED \$ IN MILLIONS	Pro Forma ¹	
	12 Months Ended	
	12/31/19	12/31/20
Revenue	\$146.2	\$142.5
Trans Adj. ²	(\$0.9)	(\$0.3)
PF Revenue	\$145.3	\$142.3
Net Income	\$3.0	\$0.4
Income Taxes	\$5.5	\$2.9
Depreciation and Amortization	\$4.9	\$5.8
Interest Expense	\$6.4	\$6.7
Remeasurement of Convertible Debt	\$0.6	\$0.0
Change in Fair Value of Warrants	(\$1.4)	(\$0.0)
Other Expense	\$0.0	\$0.0
Stock Based Compensation	\$1.3	\$1.8
Other One-time Adjustments — COGS ³	\$0.3	\$1.2
Other One-time Adjustments — SGA ⁴	\$0.5	\$4.8
EBITDA	\$20.9	\$23.6
EBITDA Margin	14.4%	16.6%

Source: AC, Whizz Audited FY20 and FY19 financial statements; Tempo unaudited draft FY20 and FY19 financial statements; Management estimates

¹ Pro forma (PF) figures include the acquisitions of Compass AC Holdings, Inc. ("Advanced Circuits" or "AC") and Whizz Systems, Inc. ("Whizz Systems" or "Whizz") which are expected to close substantially concurrently with the SPAC business combination and exclude estimates of additional future acquisitions.

² PF figures are adjusted to eliminate billings from Advanced Circuits to Tempo for purchase of product.

³ Whizz Systems charges incurred of \$0.3M (FY19) and \$1.2M (FY20) for certain related party transactions which are considered non-recurring charges post combination.

⁴ Whizz Systems charges incurred of \$4.3M (FY20) for certain related party transactions and Advanced Circuits parent company management fee of \$0.5M in each of FY19 and FY20, all of which are considered non-recurring charges post combination.



Risk Factors

RISKS RELATING TO TEMPO'S BUSINESS AND INDUSTRY

- We are an early-stage company with a history of losses. We have not been profitable historically and may not achieve or maintain profitability in the future.
- Our limited operating history and rapid growth makes evaluating our current business and future prospects difficult and may increase the risk of your investment.
- The success of our business is dependent on our ability to keep pace with technological changes and competitive conditions in our industry, and our ability to effectively adapt our services as our customers react to technological changes and competitive conditions in their respective industries. We may not timely and effectively scale and adapt our existing technology, processes, and infrastructure to meet the needs of our business.
- Our operating results and financial condition may fluctuate from period to period and may fall below expectations in any particular period, which could adversely affect the market price of our common stock.
- We compete with numerous other diversified manufacturing service providers, electronic manufacturing services and design providers and others, and may face increasing competition, which could cause our operating results to suffer.
- We are dependent on a limited number of customers and end markets. A decline in revenue from, or the loss of, any significant customer, could have a material adverse effect on our financial condition and operating results.
- Customer relationships with emerging companies may present more risks than with established companies.
- We may be adversely affected by supply chain issues, including shortages of required electronic components.
- Our gross profit and gross margin are dependent on a number of factors, including our product mix, market prices, labor costs and availability, acquisitions we may make and our ability to achieve cost synergies, level of capacity utilization and component, material, and other services prices.
- Our failure to meet our customers' price expectations may adversely affect our business and results of operations.
- If demand for our products does not grow as expected, or develops more slowly than expected, our revenues may stagnate or decline, and our business may be adversely affected.
- Defects in shipped products that give rise to product returns or warranty or other claims could result in material expenses, diversion of management time and attention, adversely affect customer relationships and damage to our reputation.
- We may be involved in legal proceedings, including intellectual property ("IP"), anti-competition and securities litigation, employee-related claims and regulatory investigations, which could, among other things, divert efforts of management and result in significant expense and loss of our IP rights.
- Our operations could suffer if we are unable to attract and retain key management or other key employees.
- The effect of COVID-19 on our operations and the operations of our customers, suppliers and logistics providers has had, and may continue to have, a material and adverse impact on our financial condition and results of operations.



Risk Factors (continued)

RISKS RELATING TO TEMPO'S BUSINESS AND INDUSTRY (CONTINUED)

- We purchase a significant amount of the materials and components we use from a limited number of suppliers. If our suppliers become unavailable or inadequate, our customer relationships, results of operations and financial condition may be adversely affected. Our facilities, and our suppliers' and our customers' facilities, are vulnerable to disruption due to natural or other disasters, public health crises, strikes and other events beyond our control.
- Our facilities, and our suppliers' and our customers' facilities, are vulnerable to disruption due to natural or other disasters, public health crises, strikes and other events beyond our control.
- If we fail to grow our business as anticipated, our operating results will be adversely affected. If we grow as anticipated but fail to manage our operations and costs accordingly, our business may be harmed and our results of operations may suffer.
- As we acquire and invest in companies or technologies, we may not realize expected business, expected cost synergies, or technological or financial benefits. The acquisitions or investments could prove difficult to integrate, disrupt our business, dilute stockholder value and adversely affect our business, results of operations, and financial condition.
- We may require additional capital to support business growth, and this capital might not be available on acceptable terms, if at all.
- We could be subject to warranty and other claims involving allegedly defective products that we supply.
- Failure of our global operations to comply with anti-corruption laws and various trade restrictions, such as sanctions and export controls, could have an adverse effect on our business.
- Compliance or the failure to comply with current and future environmental, health and safety, product stewardship and producer responsibility laws or regulations could cause us significant expense.
- We collect, use, store, or otherwise process confidential customer information, which subjects us to privacy and data security laws and contractual commitments, and our actual or perceived failure to comply with such laws and commitments could harm our business.
- An inability to successfully manage the procurement, development, implementation or execution of IT systems, or to adequately maintain these systems and their security, as well as to protect data and other confidential information, may adversely affect our business and reputation.
- If we experience a significant cybersecurity breach or disruption in our information systems or any of our partners' information systems, our business could be adversely affected.
- We rely on our information technology systems to manage numerous aspects of our business and a disruption of these systems could adversely affect our business.
- Our current levels of insurance may not be adequate for our potential liabilities.
- Because our industry is rapidly evolving, forecasts of market growth in this presentation may not be accurate, and even if the markets in which we compete achieve the forecasted growth, there can be no assurance that our business will grow at similar rates, or at all.
- Global economic, political and social conditions and uncertainties in the markets that we serve may adversely impact our business.



Risk Factors (continued)

RISKS RELATING TO TEMPO'S BUSINESS AND INDUSTRY (CONTINUED)

- We are subject to taxes in numerous jurisdictions. The Company's future effective tax rates could be affected by changes in the mix of earnings in jurisdictions with differing statutory rates and changes in tax laws or their interpretation.
- Our industry routinely experiences cyclical market patterns and our products are used across different end markets. A significant downturn in the industry or in any of these end markets could cause a meaningful reduction in demand for our products and harm our operating results.
- Third-party lawsuits and assertions to which we are subject alleging our infringement of patents, trade secrets or other intellectual property rights may have a significant adverse effect on our financial condition.
- We may incur substantial costs enforcing and defending our intellectual property rights.
- If we are unable to adequately protect or enforce our intellectual property rights, such information may be used by others to compete against us.
- Our internal controls over financial reporting currently do not meet all of the standards contemplated by Section 404 of the Sarbanes-Oxley Act of 2002 (the "Sarbanes-Oxley Act"), and failure to achieve and maintain effective internal controls over financial reporting in accordance with Section 404 of the Sarbanes-Oxley Act could impair our ability to produce timely and accurate financial statements or comply with applicable regulations and have a material adverse effect on our business.
- Fluctuations in the cost and availability of raw materials, equipment, labor, and transportation could cause manufacturing delays or increase our costs.
- Certain software we use is from open source code sources, which, under certain circumstances could materially adversely affect our business, financial condition, and operating results.

RISKS RELATED TO BECOMING A PUBLIC COMPANY

- We will incur increased costs as a result of operating as a public company, and our management will be required to devote substantial time to new compliance and investor relations initiatives.
- Members of our management team and board of directors have limited experience managing a public company.
- We are an "emerging growth company" and a "smaller reporting company" and the reduced disclosure requirements applicable to emerging growth companies and smaller reporting companies may make our common stock less attractive to investors, and may make it more difficult to compare our performance with other public companies.
- If we are unable to meet expectations and projections in any research or reports published by securities or industry analysts, or if securities or industry analysts do not publish research or reports or publish unfavorable research or reports about our business, our stock price and trading volume could decline, or there may be a depressed market price and limited liquidity for our securities.
- If we fail to maintain proper and effective internal controls over financial reporting, our ability to produce accurate and timely financial statements could be impaired, investors may lose confidence in our financial reporting and the trading price of our common stock may decline.
- Our disclosure controls and procedures may not prevent or detect all errors or acts of fraud.



Risk Factors (continued)

RISKS RELATED TO BECOMING A PUBLIC COMPANY (CONTINUED)

- Changes in accounting rules and regulations, or interpretations thereof, could result in unfavorable accounting charges or require us to change our compensation policies.
- Provisions in our proposed charter documents and under Delaware law could discourage a takeover that stockholders may consider favorable and may lead to entrenchment of management.
- Our proposed certificate of incorporation will provide that the Court of Chancery of the State of Delaware will be the exclusive forum for substantially all disputes between us and our stockholders and that the federal district courts shall be the exclusive forum for the resolution of any complaint asserting a cause of action arising under the U.S. Securities Act of 1933, as amended, which could limit our stockholders' ability to obtain a favorable judicial forum for disputes with us or our directors, officers or employees.

RISKS RELATED TO THE BUSINESS COMBINATION AND ACE

- Each of ACE Convergence Acquisition Corp. ("ACE") and Tempo Automation, Inc. ("Tempo") will incur significant transaction costs in connection with the business combination between ACE and Tempo (the "Business Combination").
- The announcement of the proposed Business Combination could disrupt Tempo's relationships with its customers, suppliers, business partners and others, as well as its operating results and business generally.
- The consummation of the Business Combination is subject to a number of conditions, including, among other things, the consummation of the acquisitions by Tempo of each of Whizz Systems, Inc. and Compass AC Holdings, Inc. (collectively, the "Add-on Acquisitions") and all required waiting periods or approvals under the Hart-Scott-Rodino Antitrust Improvements Act of 1976 and all applicable antitrust laws relating to the Business Combination and the Add-On Acquisitions having expired, been received or terminated, as applicable, which conditions may not be satisfied on a timely basis, if at all. If those conditions are not satisfied or waived, the merger agreement may be terminated in accordance with its terms and the Business Combination may not be completed. The Add-on Acquisitions are also subject to a number of conditions, which, if not satisfied or waived, may prevent the Business Combination from being completed.
- If ACE is not able to complete the Business Combination by January 30, 2022, nor able to complete another business combination by such date, in each case, as such date may be further extended pursuant to ACE's current amended and restated memorandum of association under the Cayman Islands Companies Act and ACE's current amended and restated articles of association, ACE would cease all operations except for the purpose of winding up and would redeem its Class A ordinary shares and liquidate the trust account, in which case its public shareholders may only receive approximately \$10.00 per share and its warrants will expire worthless.
- If the net proceeds of ACE's initial public offering not being held in the trust account are insufficient to allow ACE to operate through to January 30, 2022 and ACE is unable to obtain additional capital, ACE may be unable to complete its initial business combination, in which case its public shareholders may only receive \$10.00 per share, and its warrants will expire worthless.
- Compliance obligations under the Sarbanes-Oxley Act may make it more difficult to effectuate the Business Combination, require substantial financial and management resources and increase the time and costs of completing a business combination.
- The ability to successfully effect the Business Combination and the combined company's ability to successfully operate the business thereafter will be largely dependent upon the efforts of certain key personnel. The loss of such key personnel could negatively impact the operations and financial results of the combined business.



Risk Factors (continued)

RISKS RELATED TO THE BUSINESS COMBINATION AND ACE (CONTINUED)

- There is no assurance that a stockholder's decision whether to redeem its shares for a pro rata portion of ACE's trust account will put the stockholder in a better future economic position.
- If the Business Combination's benefits do not meet the expectations of investors or securities analysts, the market price of ACE's securities or, following the consummation of the Business Combination, the combined company's securities, may decline.
- A market for the combined company's securities may not develop, which would adversely affect the liquidity and price of such securities.
- There can be no assurance that the combined company's securities will be approved for listing on the Nasdaq Stock Market LLC ("Nasdaq") or that the combined company will be able to comply with the continued listing standards of Nasdaq.
- Directors of ACE have potential conflicts of interest in recommending that ACE's stockholders vote in favor of the adoption of the Business Combination.
- ACE may redeem unexpired warrants prior to their exercise at a time that is disadvantageous to the holders of ACE warrants, thereby making such warrants worthless.
- ACE's warrants are accounted for as liabilities and the changes in value of ACE's warrants could have a material effect on Tempo's financial results.
- Even if the Business Combination is completed, there can be no assurance that ACE's warrants will be in the money during their exercise period, and they may expire worthless.
- If ACE seeks stockholder approval of the Business Combination, its sponsor, directors, officers, advisors and their affiliates may elect to purchase shares or warrants from public stockholders, which may influence a vote on the Business Combination and reduce the public "float" of ACE's securities.
- If ACE seeks stockholder approval of the Business Combination, its sponsor, officers and directors have agreed to vote in favor of such Business Combination, regardless of how its public stockholders vote.
- The ability of ACE's public stockholders to exercise redemption rights with respect to a large number of its shares could increase the probability that the Business Combination would be unsuccessful.
- ACE is not required to obtain an opinion from an independent investment banking firm or from an independent accounting firm, and consequently, its stockholders may have no assurance from an independent source that the price it is paying for the business is fair to ACE from a financial point of view.
- Neither the ACE board of directors nor any committee thereof obtained a third party valuation in determining whether or not to pursue the Business Combination.
- Legal proceedings in connection with the Business Combination, the outcomes of which are uncertain, could delay or prevent the completion of the Business Combination.
- ACE has identified a material weakness in its internal control over financial reporting as of December 31, 2020. If ACE is unable to develop and maintain an effective system of internal control over financial reporting, it may not be able to accurately report its financial results in a timely manner, which may adversely affect investor confidence in it and materially and adversely affect its business and operating results.
- ACE has been subject to inquiries by the U.S. Securities and Exchange Commission (the "SEC") since May 2021 regarding certain disclosures in its Registration Statement on Form S-4, filed with the SEC on February 10, 2021, as amended on March 19, 2021, April 9, 2021 and May 6, 2021, and such inquiries remain ongoing. Such inquiries may materially adversely affect ACE or the combined company.



Risk Factors (continued)

RISKS RELATED TO THE BUSINESS COMBINATION AND ACE (CONTINUED)

- Subsequent to consummation of the Business Combination, the combined company may be exposed to unknown or contingent liabilities and may be required to subsequently take write-downs or write-offs, restructuring and impairment or other charges that could have a significant negative effect on its financial condition, results of operations and its share price, which could cause you to lose some or all of your investment.
- Future resales of common stock after the consummation of the Business Combination may cause the market price of the combined company's securities to drop significantly, even if its business is doing well.
- The public stockholders of ACE will experience immediate dilution as a consequence of the issuance of common stock as consideration in the Business Combination and the private placement and due to future issuances pursuant to the combined company's equity plan(s).
- The combined company may issue additional equity securities without your approval, which would dilute your ownership interests and may depress the market price of our securities.
- The domestication of ACE as a Delaware corporation may result in adverse tax consequences for holders of ACE securities.
- The Business Combination or combined company may be materially adversely affected by the recent COVID-19 outbreak.
- The price of the combined company's securities may be volatile.
- Changes in laws or regulations, or a failure to comply with any laws or regulations, may adversely affect ACE's and the combined company's business, including ACE's ability to consummate the Business Combination, and ACE's and the combined company's results of operations.



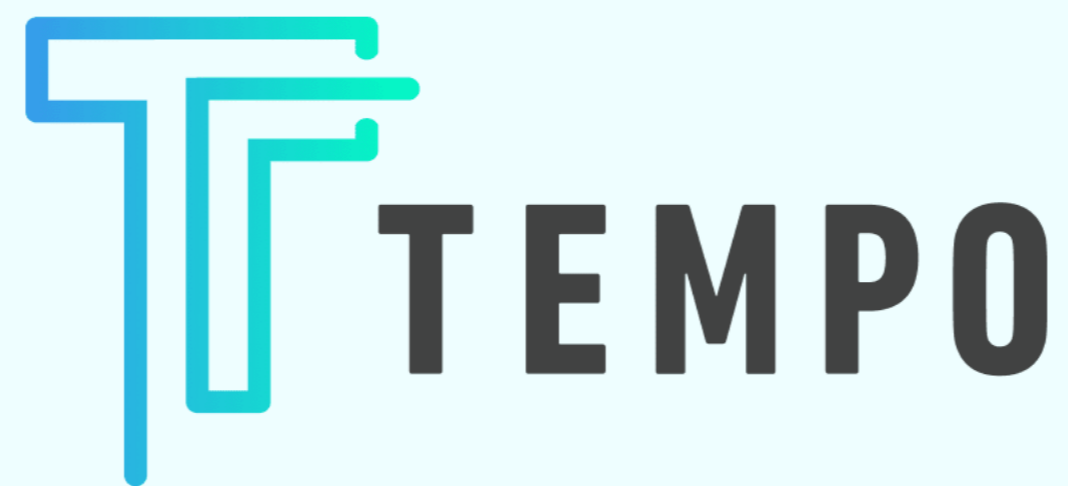

WWW.TEMPOAUTOMATION.COM